

Normal tissue damage

Understanding molecular pathways to propose new therapies



*MC Vozenin-Brotans, PhD, HDR
UPRES EA 27-10, IRSN/IGR Villejuif-France*

Intestine: a major dose limiting organ

Patients treated with radical radiotherapy each year for pelvic cancer :

30 000 in France, *Haydont et al., BJR, 2007*

12 000 in the UK, *Andreyev, Gut, 2005*

3M in the USA, *Hauer-Jensen et al., Acta Oncol, 2003*

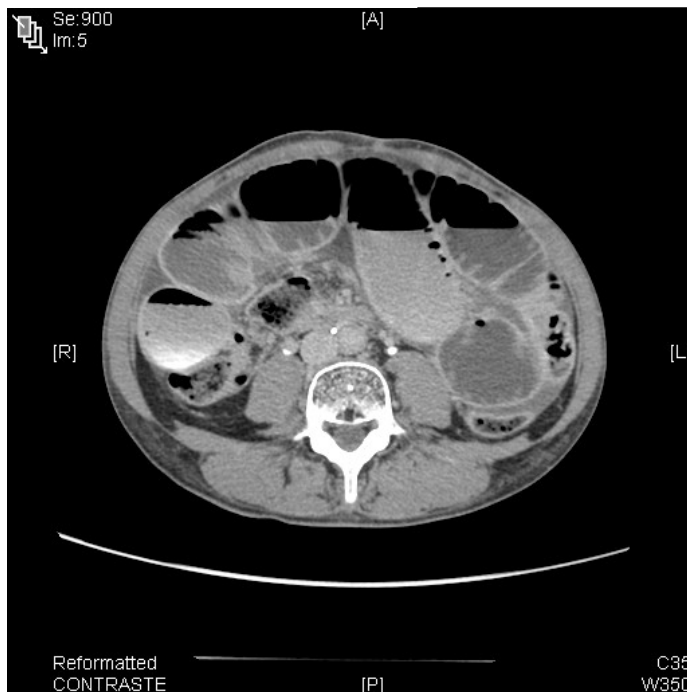

Affects patients' quality of life and treatment outcome

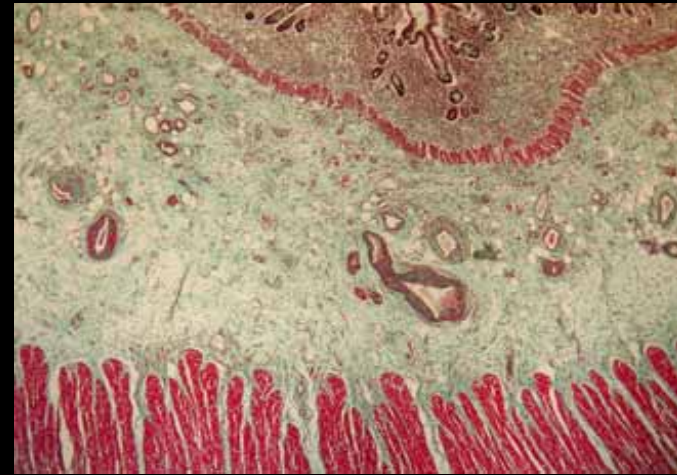

The main feature of delayed radiation-induced toxicity is **fibrosis**

VOLUME 23 · NUMBER 24 · DECEMBER 1 2005

JOURNAL OF CLINICAL ONCOLOGY

E D I T O R I A L

The Irreversibility of Radiation-Induced Fibrosis: Fact or Folklore?

Mitchell S. Anscher, *Department of Radiation Oncology, Duke University Medical Center, Durham, NC*

- Antifibrotic treatment aiming at Reversing established fibrosis is highly needed**
- No interference with anti-tumor treatment
 - Focused treatment to the patients who need it

Radiation-induced fibrosis

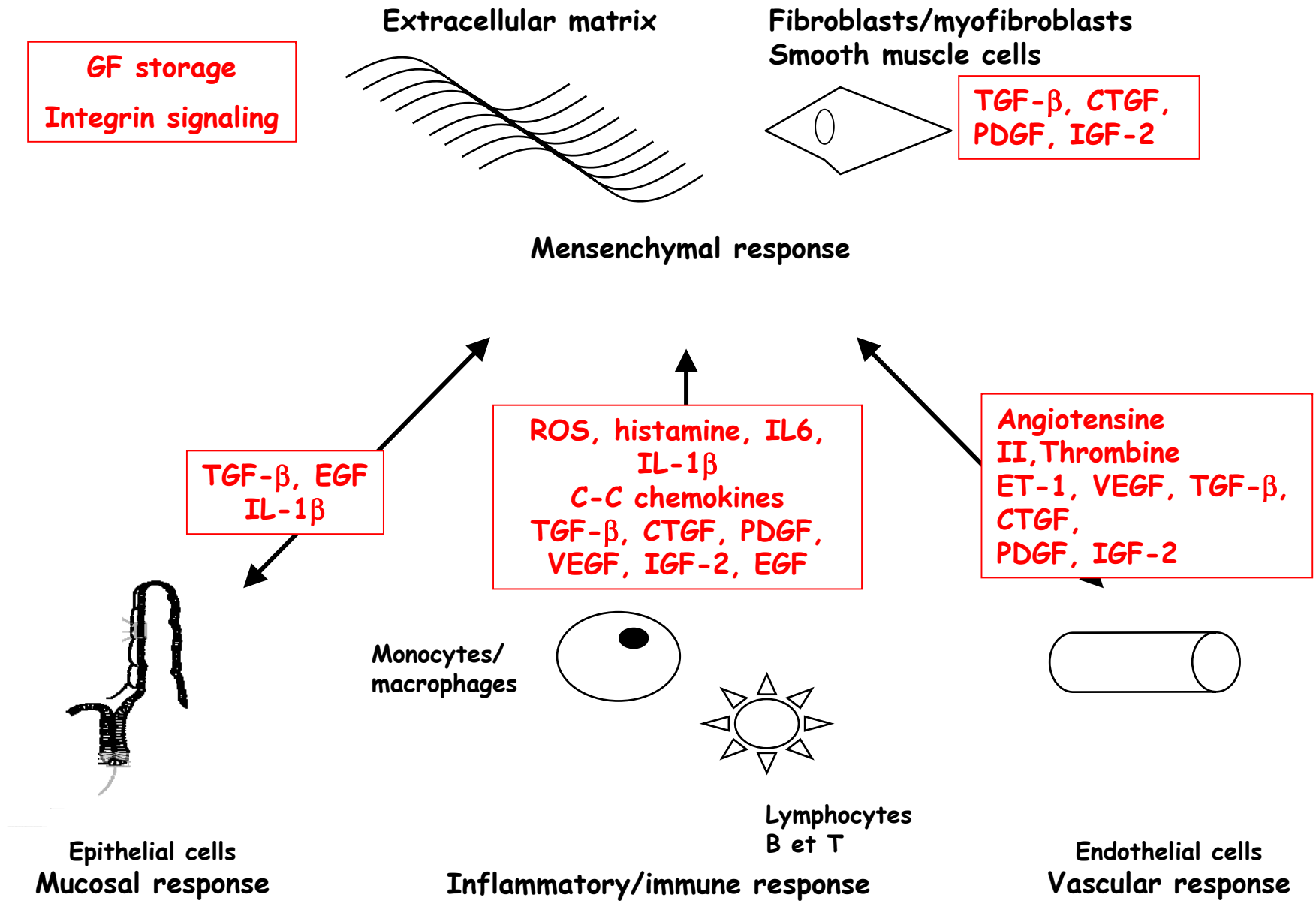

Radiation enteropathy



V Haydont
C Bourgier
O Gilliot
S Rivera

Pr. M Pocard, IGR Surgery department

Dr. A Lusinchi, IGR Radiotherapy department

Dr P Crenn, APHP A Paré



Pravastatin gift : Dr E Amelineau, BMS, Fr
Supported by «le Comité de Radioprotection d'Electricité de France»
Et le contrat de recherche n°3881 de l'Association pour la Recherche sur le Cancer



Sirius red

CTGF

TGF- β

Radiation enteritis

Mucosa

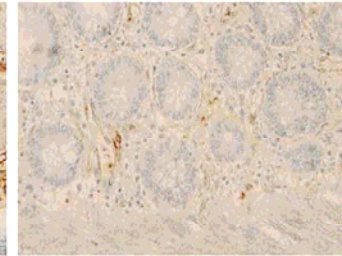
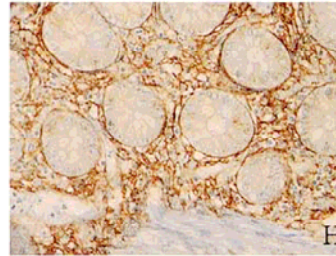
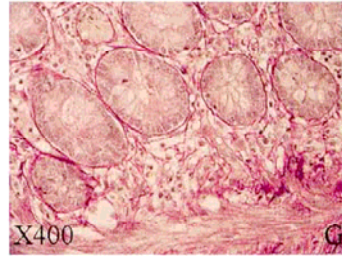

Fibrosis in the Submucosa

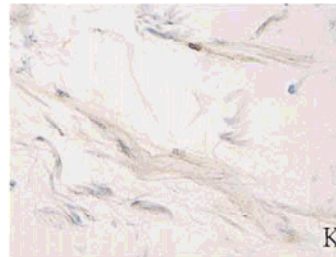
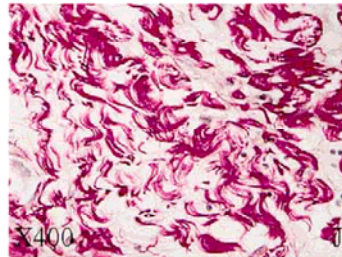

Neovessels in the fibrotic Submucosa

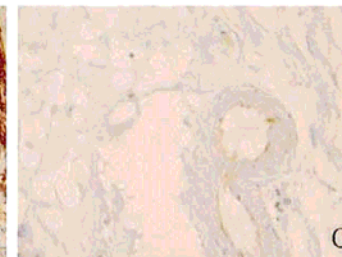
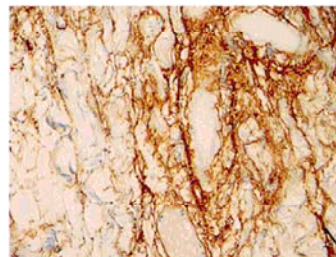
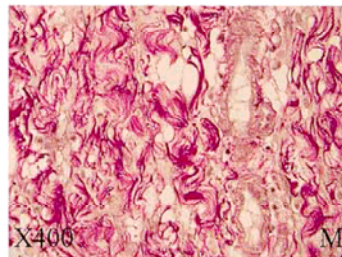

Muscularis Propria and Subserosa

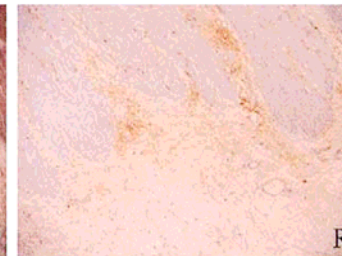
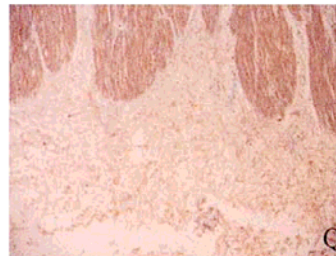
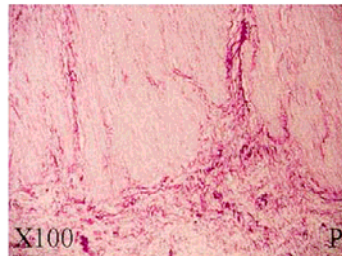

Hypothesis

Fibrosis maintenance and CTGF expression in
Radiation enteropathy
is TGF- β 1-Independent

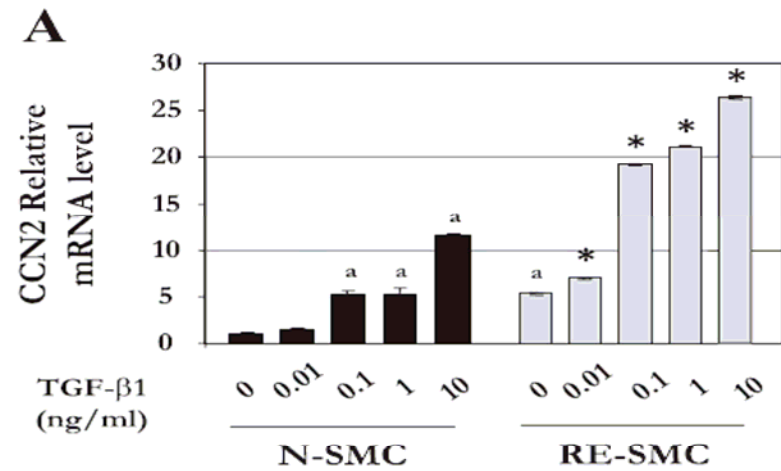
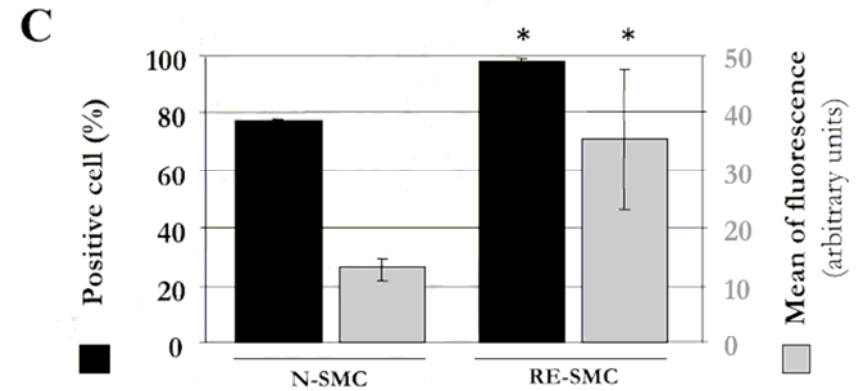
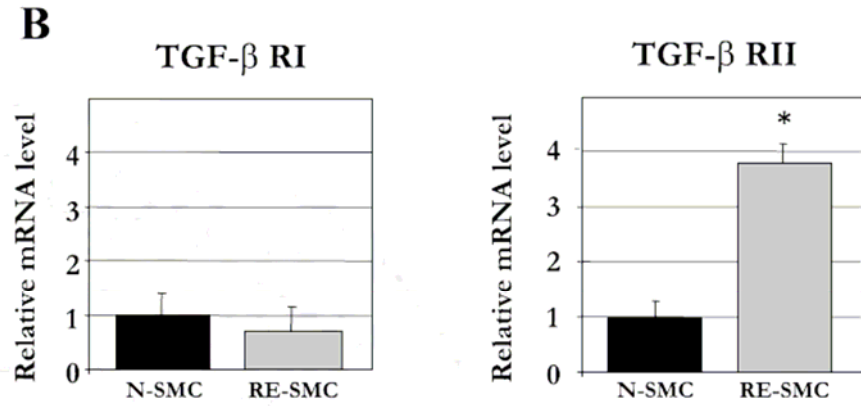
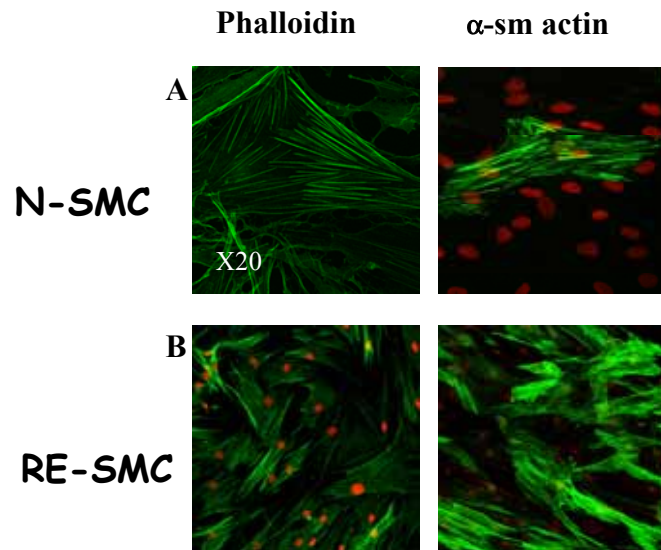
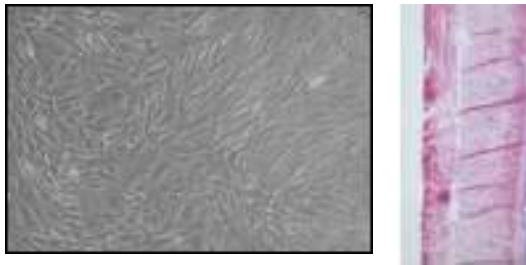
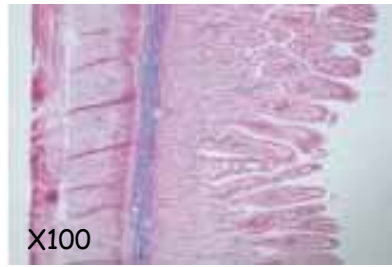

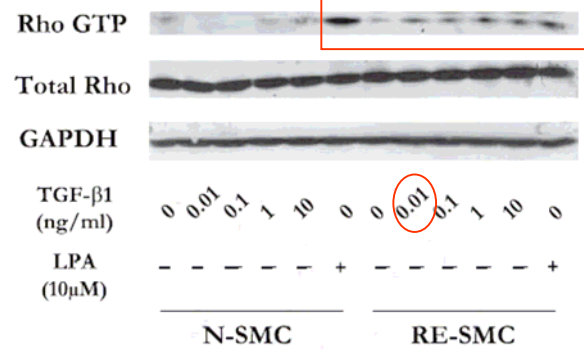
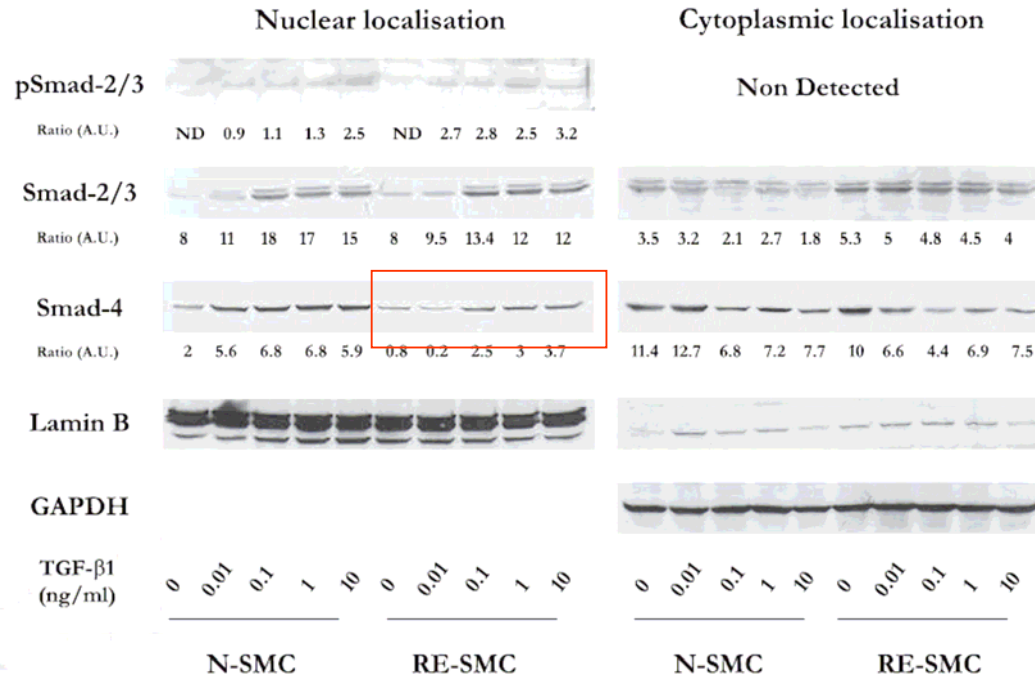
A

Bourgier et al. *Gut*, 2005
Haydont et al., *Radiother&Oncol*, 2005
Haydont et al., *Am J Physiol. Cell physiol*, 2008

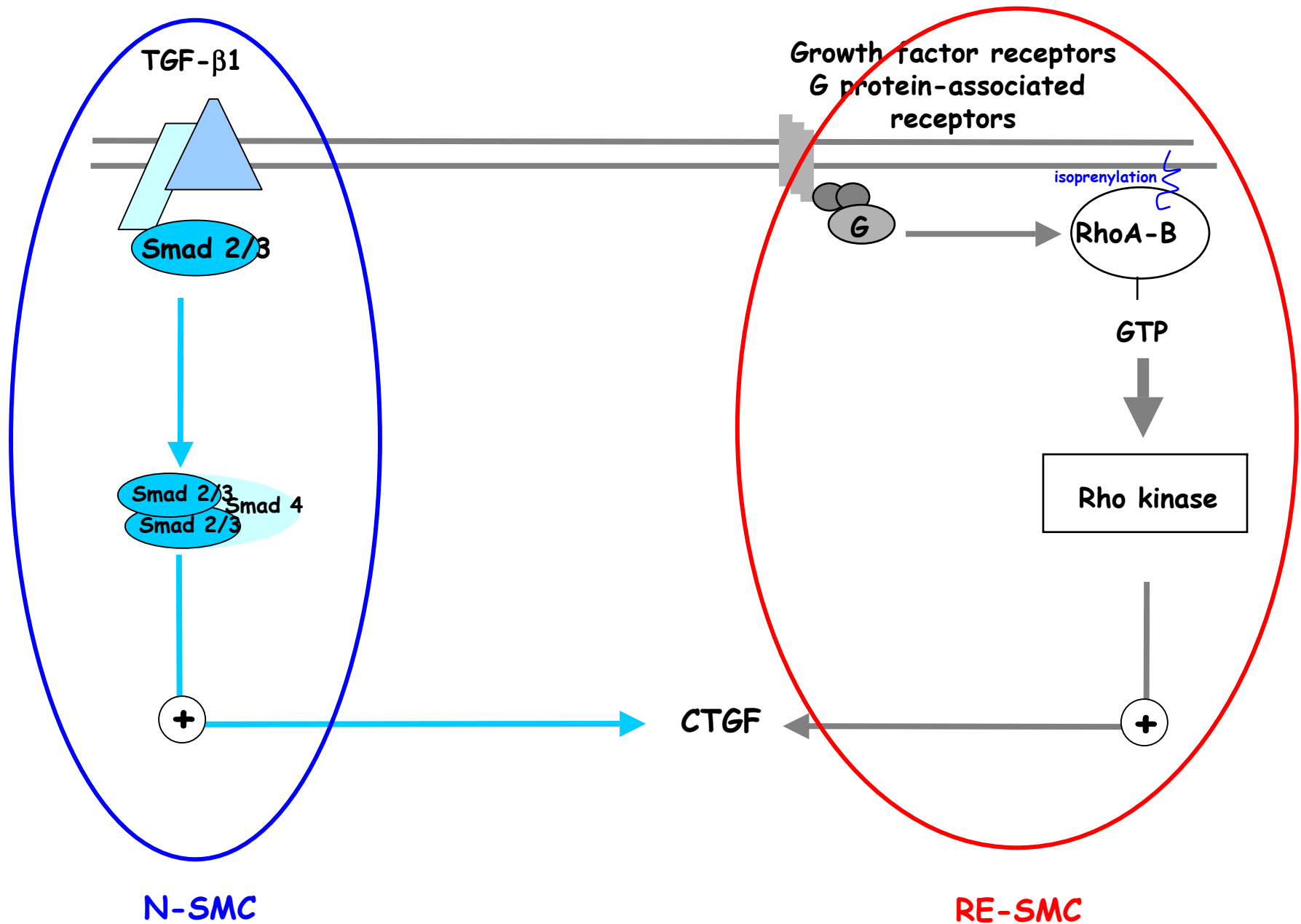

Bourgier et al. Gut, 2005
Haydont et al., Radiother&Oncol, 2005
Haydont et al., Am J Physiol. Cell physiol, 2008

Low dose of TGF-β1

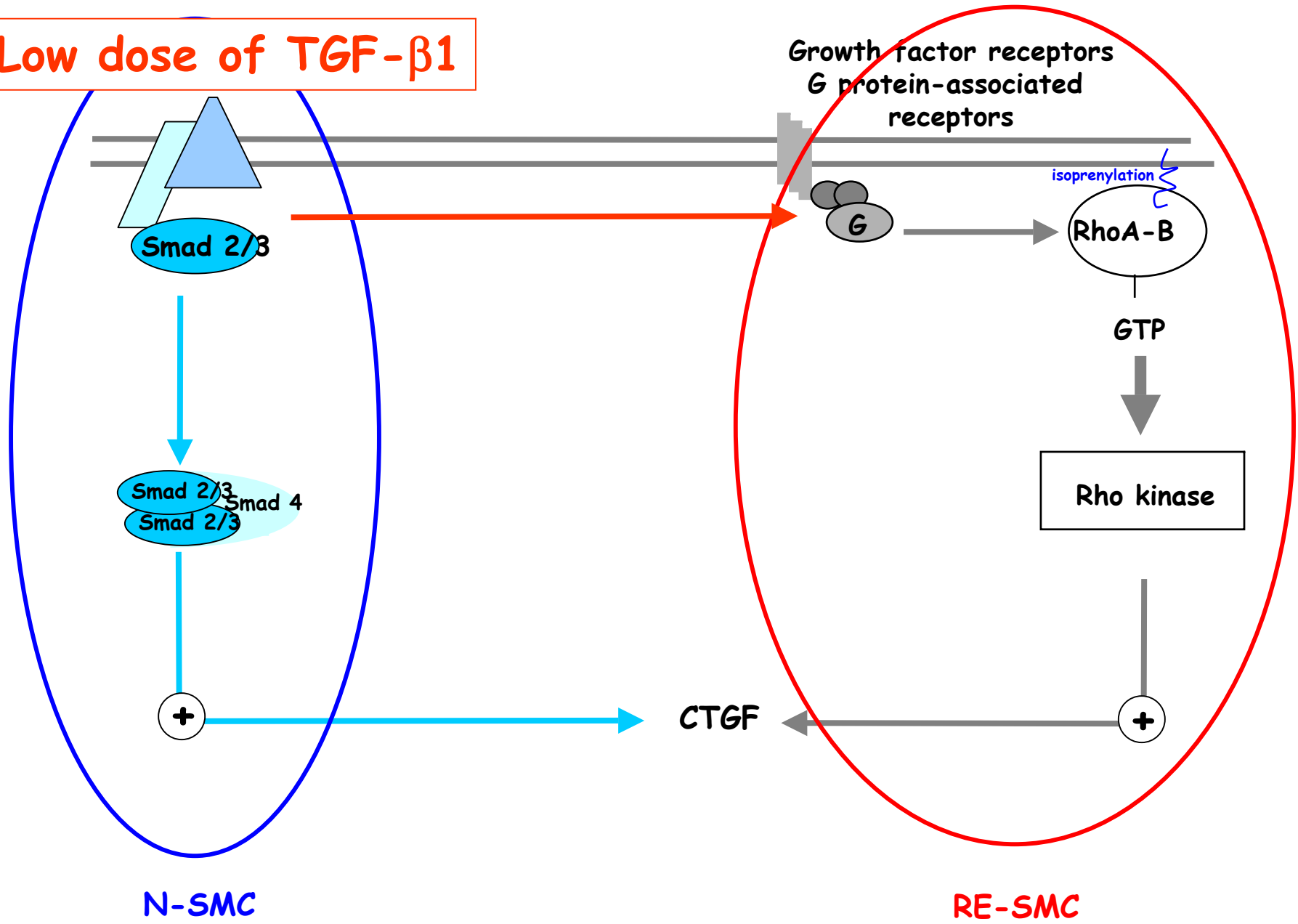

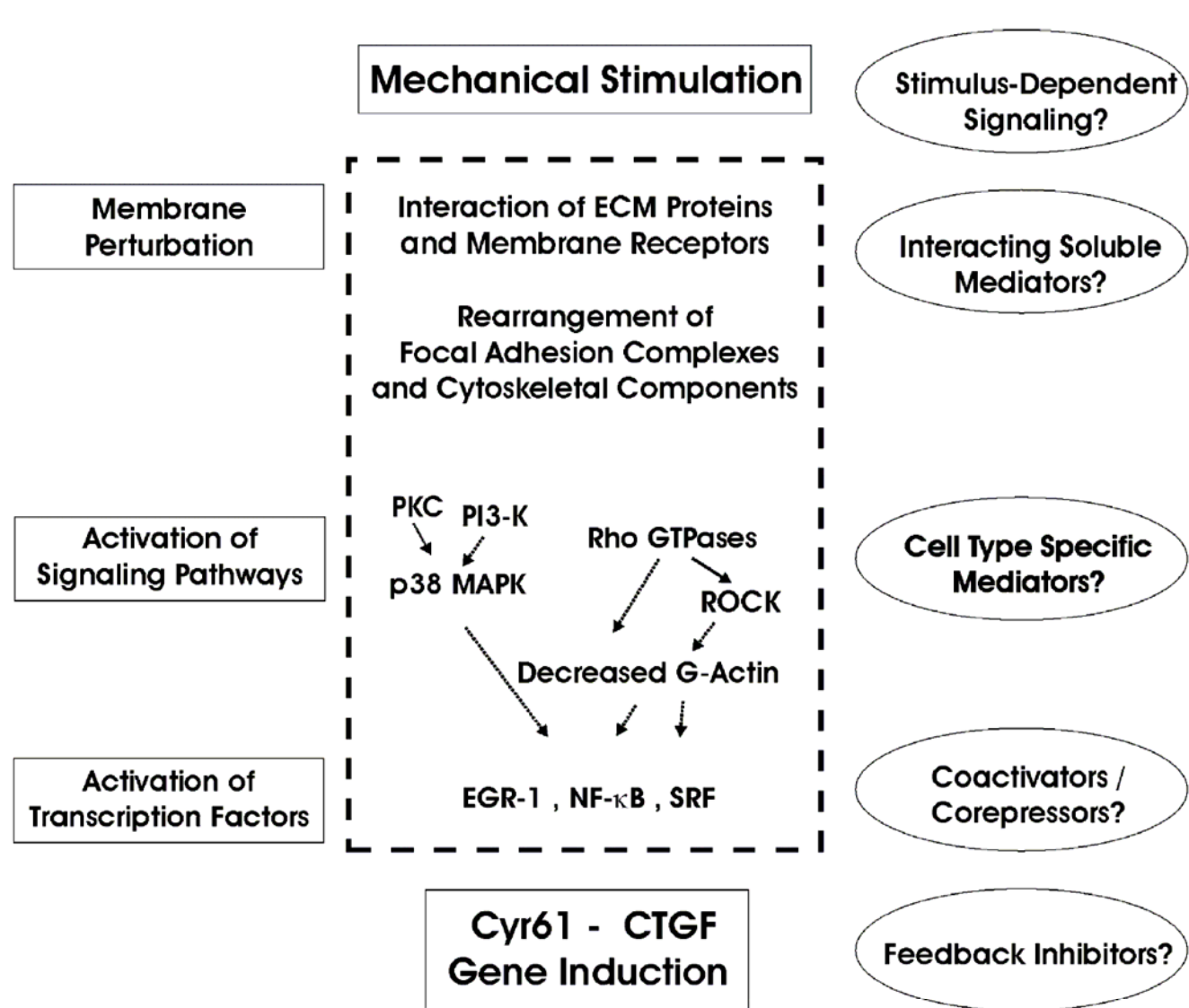

Targeting the Rho/ROCK pathway

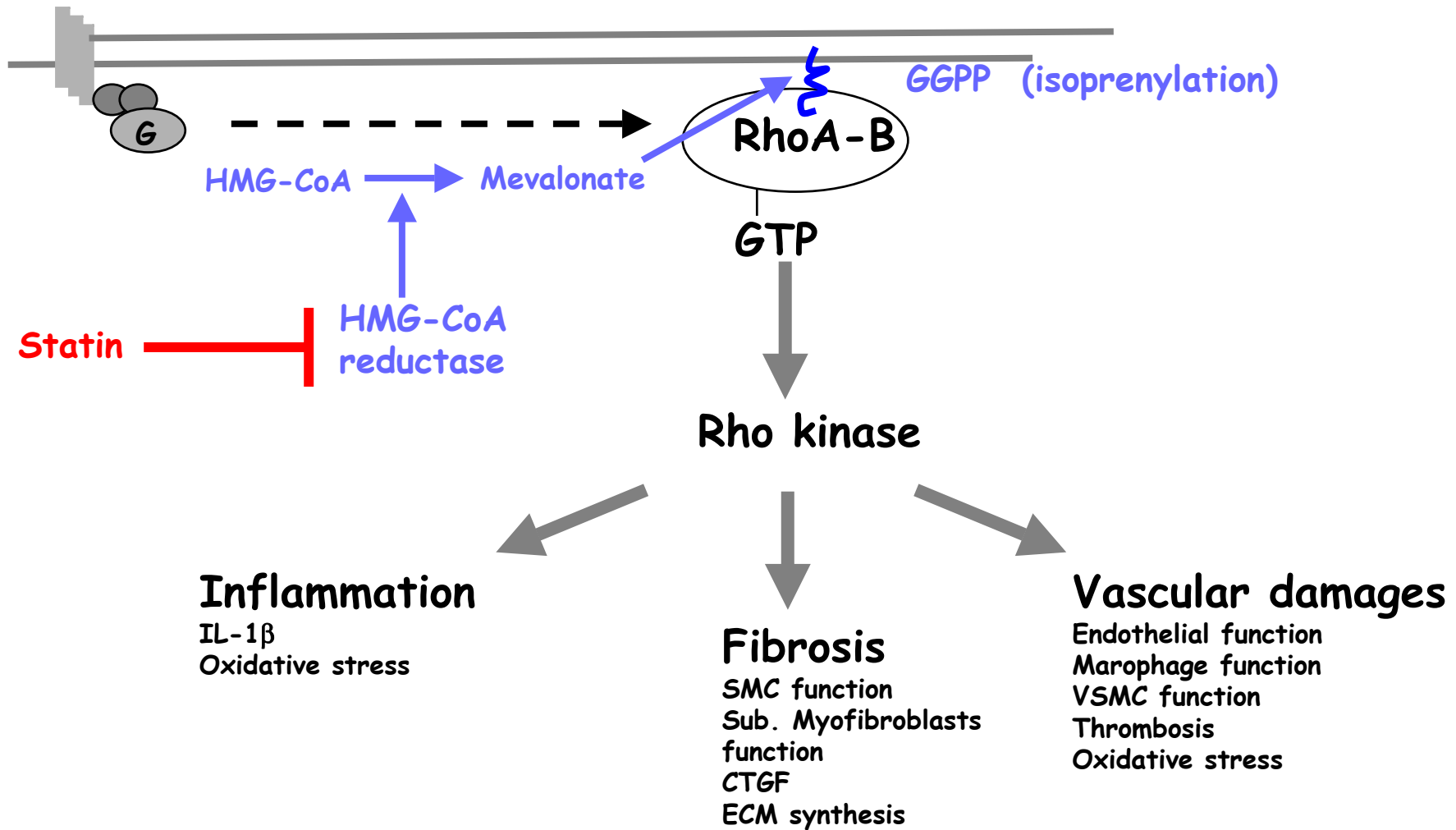

Segain et al., *Gastro*, 2004
 Rolfe et al., *Atheroscl.*, 2005

Bourgier et al., *Gut*, 2005
 Haydont et al., *R&O*, 2005

Gaugler et al., *Rad Res*, 2005
 Rolfe et al., *Atheroscl.*, 2005

Delayed radiation-induced toxicity

Therapeutic Study Rho/ROCK modulation

Prophylactic strategy

Curative strategy

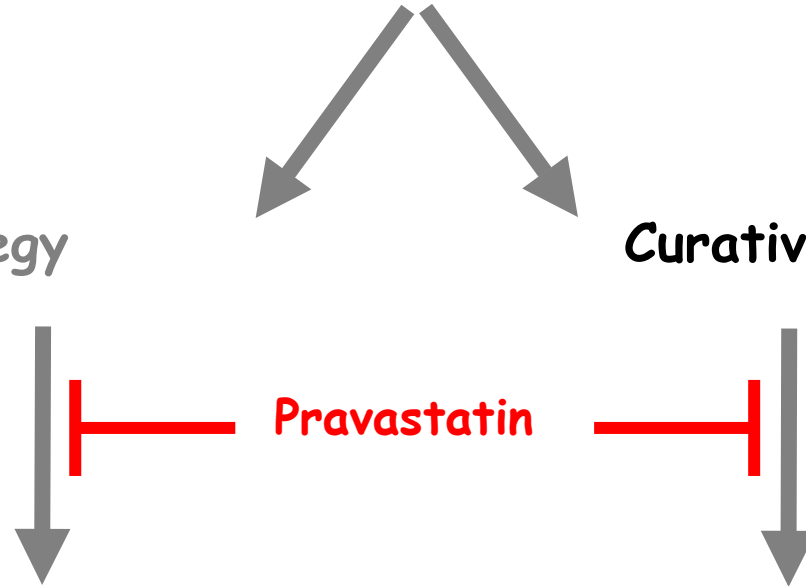

Inhibition of vascular and
mesenchyme activation

Fibrosis reversion

Thrombosis
Thrombomodulin/Thrombin

Fibrogenic growth factors
TGF- β 1/CTGF
ECM

CTGF
ECM

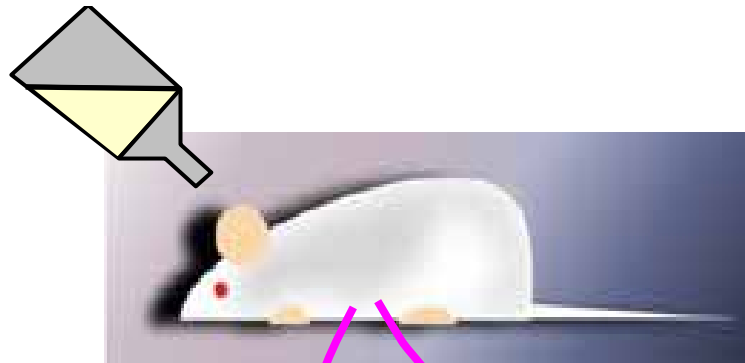

19 Gy

**Experimental radiation enteropathy :
Wistar rats (n=5-10) ileum surgically removed from the abdominal cavity
and locally irradiated et 19 Gy-RX**

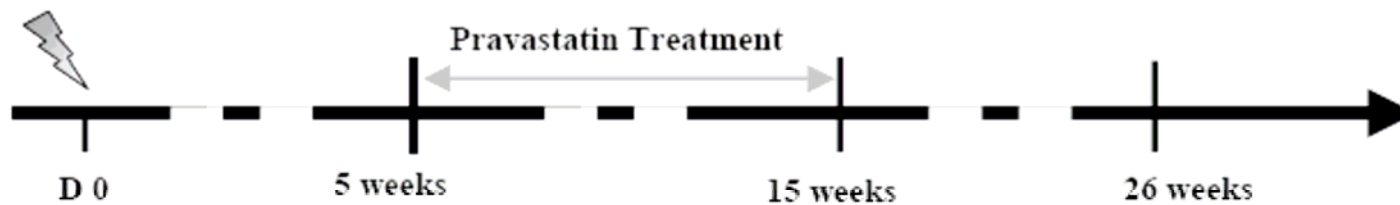

Human Cancer Biology

Pravastatin Inhibits the Rho/CCN2/Extracellular Matrix Cascade in Human Fibrosis Explants and Improves Radiation-Induced Intestinal Fibrosis in Rats

Valérie Haydont,^{1,4} Céline Bourcier,^{1,4} Marc Pocard,^{2,6} Antoine Lusinchi,³ Jocelyne Aigueperse,⁵ Denis Mathé,¹ Jean Bourhis,^{1,3} and Marie-Catherine Vozenin-Brotons^{1,4}

Fibrotic ileum

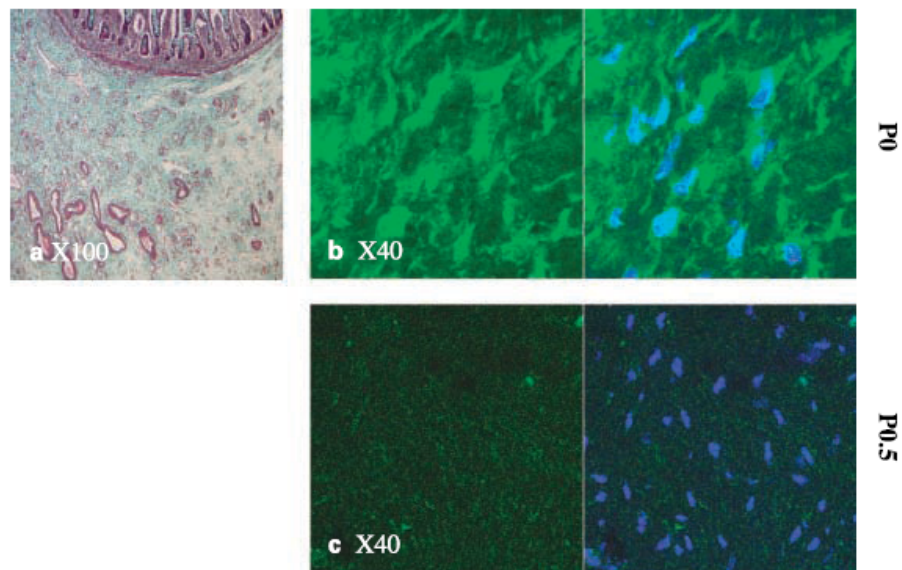

1400 μm

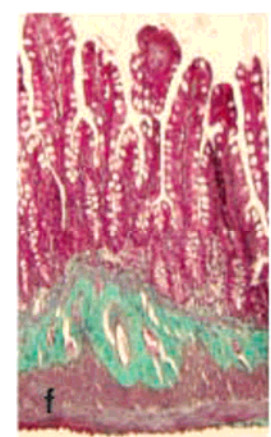
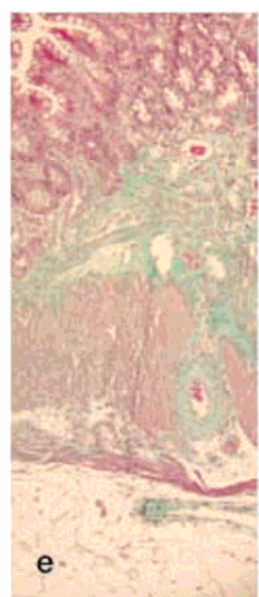

Control

Pravastatin

Fibrotic colon

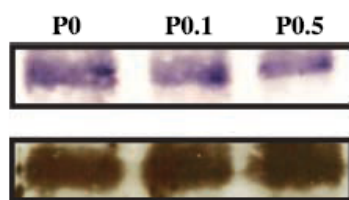

pMLC (ser19)

MLC2

Fibrotic ileum

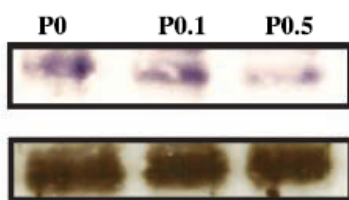

pMLC (ser19)

MLC2

Therapeutic Study Rho/ROCK modulation

Prophylactic strategy

Curative strategy

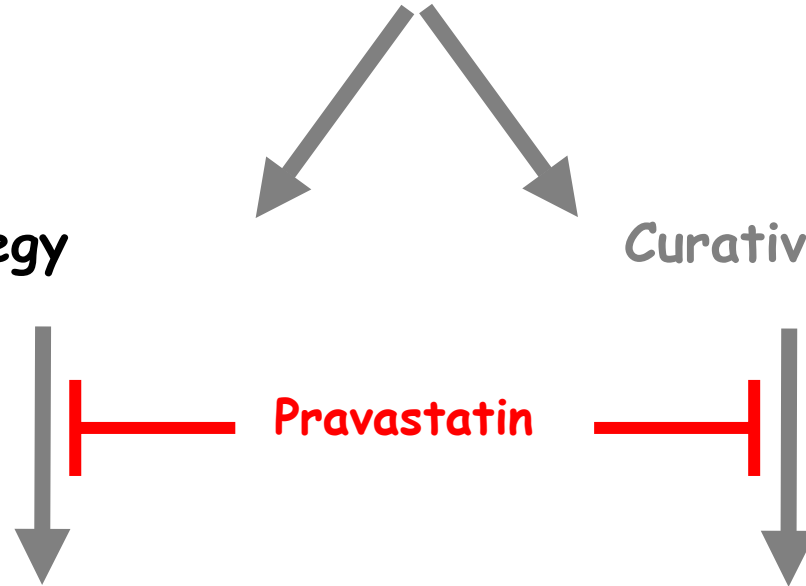

Inhibition of **vascular and mesenchyme activation**

Fibrosis reversion

Thrombosis
Thrombomodulin/Thrombin

Fibrogenic growth factors
TGF- β 1/**CTGF**
ECM

CTGF
ECM

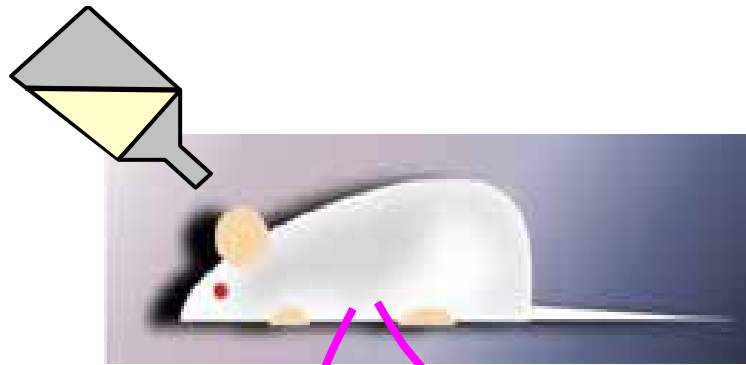

19 Gy

No RI lesion in 6/10 rats

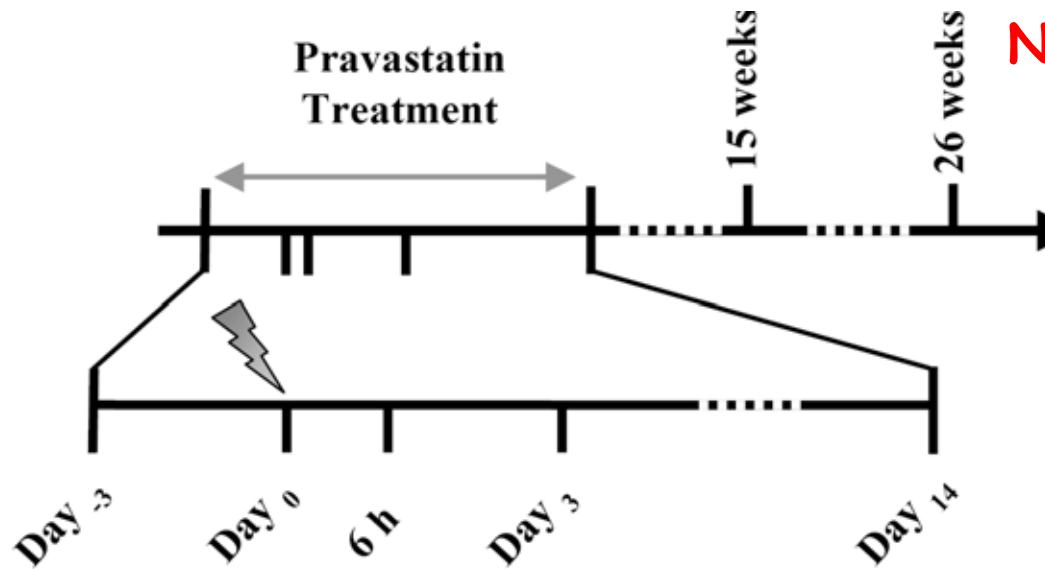

No improvement of acute phase

BIOLOGY CONTRIBUTION

SUCCESSFUL MITIGATION OF DELAYED INTESTINAL RADIATION INJURY USING PRAVASTATIN IS NOT ASSOCIATED WITH ACUTE INJURY IMPROVEMENT OR TUMOR PROTECTION

VALÉRIE HAYDONT, PH.D.,*† OLIVIER GILLIOT, M.D.,* SOFIA RIVERA, M.D.,* CÉLINE BOURGIER, M.D.,*†
 AGNÈS FRANÇOIS, PH.D.,*† JOCELYNE AIGUEPERSE, PH.D.,‡ JEAN BOURHIS, M.D., PH.D.,* AND
 MARIE-CATHERINE VOZENIN-BROTONS, PH.D.*†

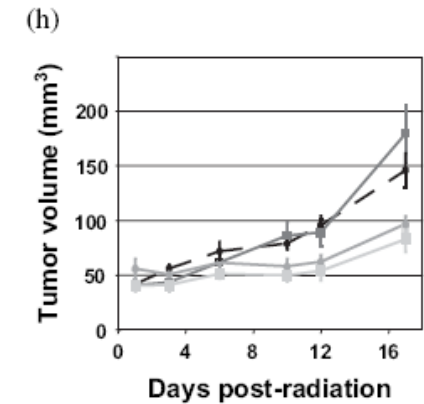
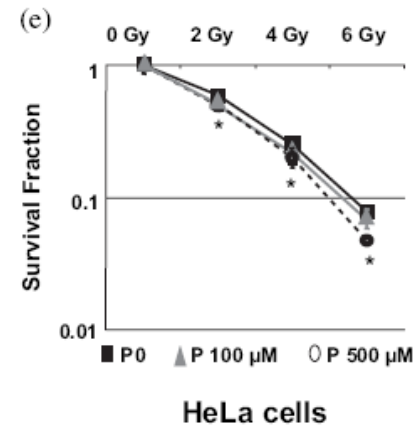
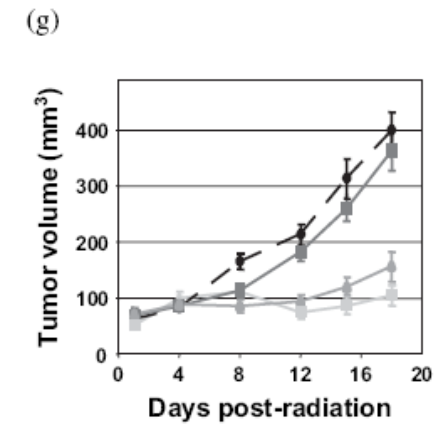
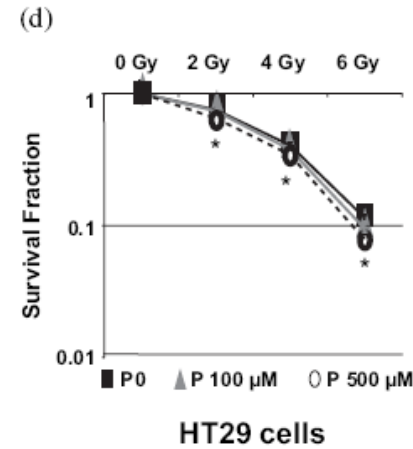
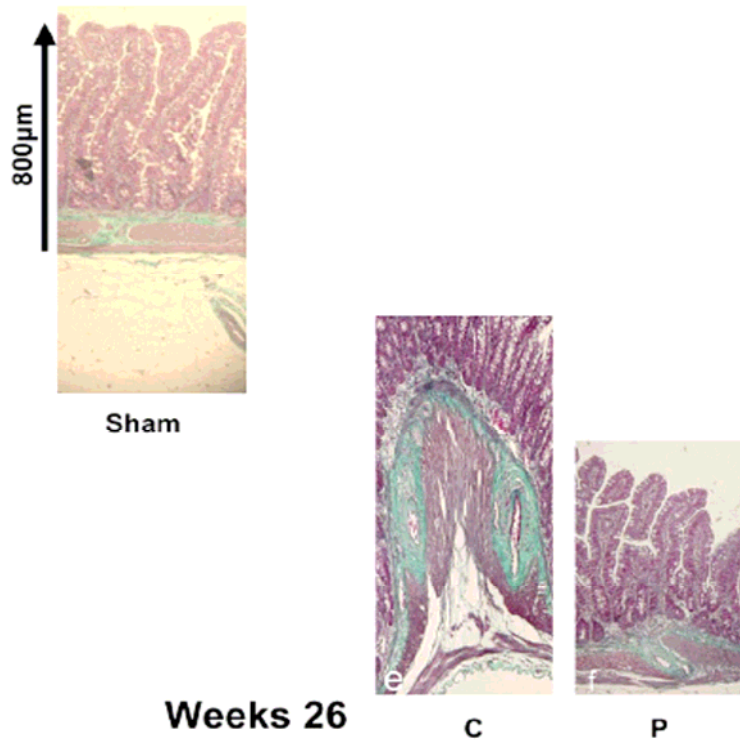



Int. J. Radiation Oncology Biol. Phys., Vol. 62, No. 5, pp. 1363–1370, 2005
Copyright © 2005 Elsevier Inc.
Printed in the USA. All rights reserved
0360-3016/05/\$—see front matter

doi:10.1016/j.ijrobp.2004.12.033

CLINICAL INVESTIGATION

Rectum

**ASSOCIATION OF STATIN USE WITH A PATHOLOGIC COMPLETE
RESPONSE TO NEOADJUVANT CHEMORADIATION FOR RECTAL CANCER**

MATTHEW S. KATZ, M.D.,* BRUCE D. MINSKY, M.D.,* LEONARD B. SALTZ, M.D.,[†]
ELYN RIEDEL, M.A.,[‡] DAVID B. CHESSIN, M.D.,[§] AND JOSE G. GUILLEM, M.D.[§]

Departments of *Radiation Oncology, [†]Medicine, [‡]Biostatistics, and [§]Surgery, Memorial Sloan-Kettering Cancer Center,
New York, NY

BIOLOGY CONTRIBUTION

SIMVASTATIN AMELIORATES RADIATION ENTEROPATHY DEVELOPMENT AFTER LOCALIZED, FRACTIONATED IRRADIATION BY A PROTEIN C-INDEPENDENT MECHANISM

JUNRU WANG, M.D., PH.D.,* MARJAN BOERMA, PH.D.,† QIANG FU, M.D., PH.D.,§
 ASHWINI KULKARNI, M.S.,* LOUIS M. FINK, M.D.,¶ AND MARTIN HAUER-JENSEN, M.D., PH.D.*†||

1486

I. J. Radiation Oncology ● Biology ● Physics

Volume 68, Number 5, 2007

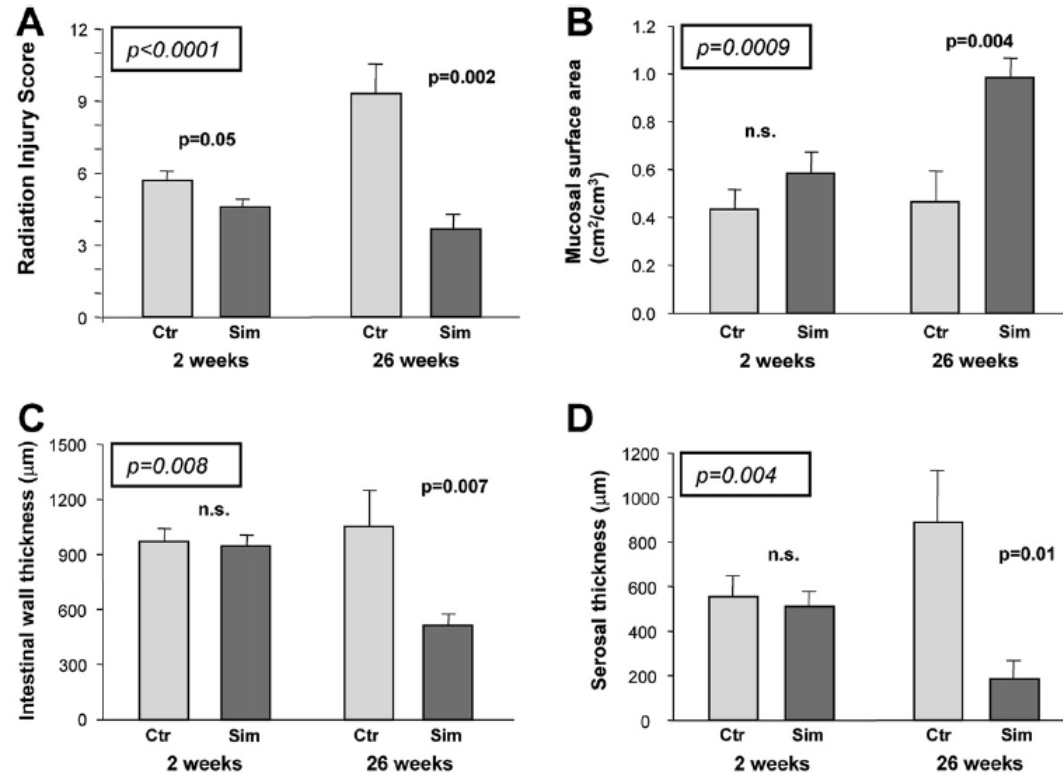
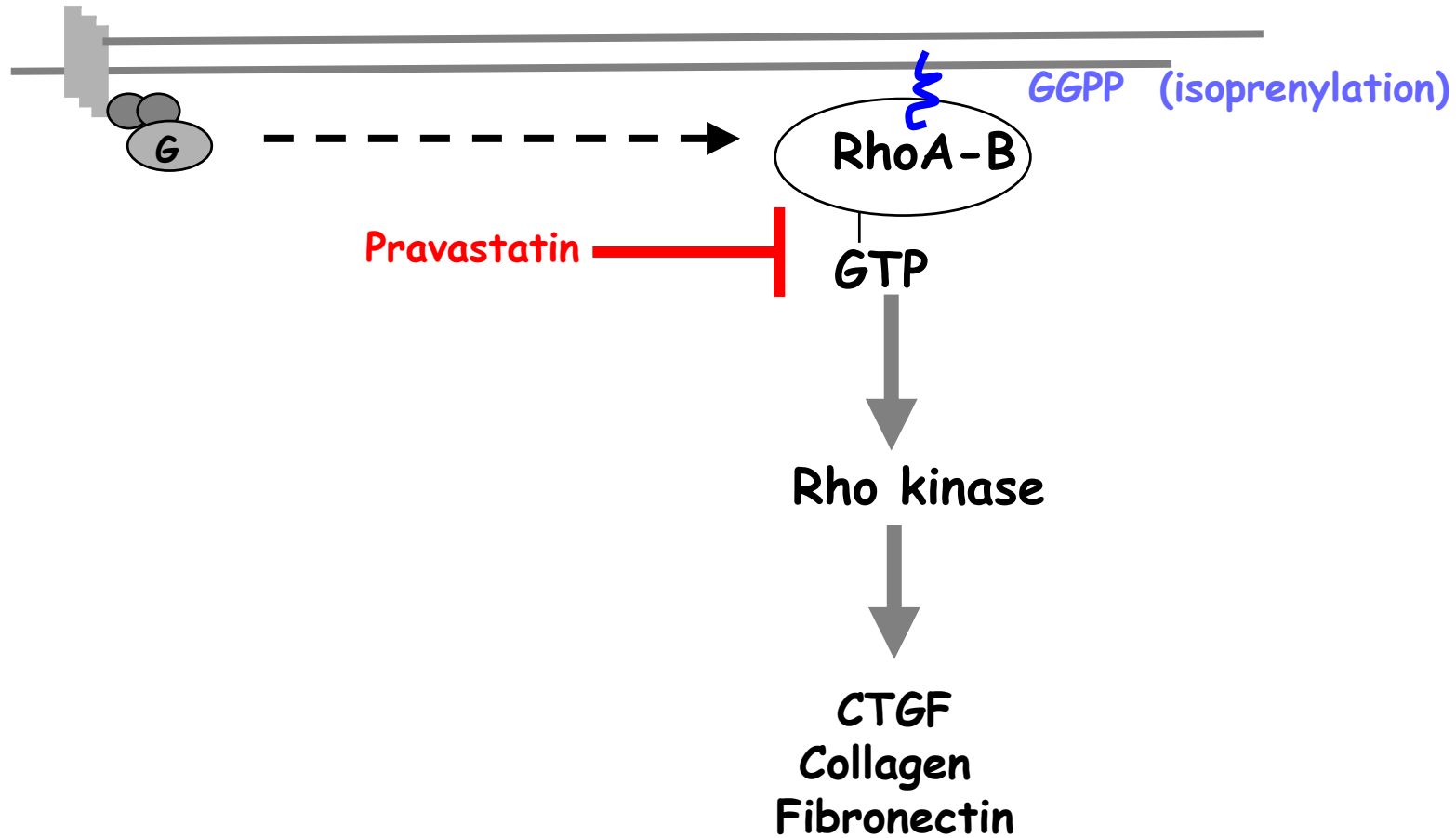

Fig. 1. Effect of simvastatin administration on structural alterations after localized, fractionated irradiation of rat small intestine. (A) Radiation injury score; (B) mucosal surface area; (C) intestinal wall thickness; (D) serosal thickness. The significance levels from the analysis of variance, with observation time and simvastatin administration as factors, are enclosed in a box and italicized. Significance levels for the univariate comparison at each time point are also provided.

Targeting the Rho/ROCK/CTGF pathway to prevent and reverse RI fibrosis



Transfer into the clinic :
Phase II/III trial in patients treated for pelvic cancer

Is Rho/ROCK activation specific to radiation enteropathy?

Lung fibrosis



Dr Paule Opolon

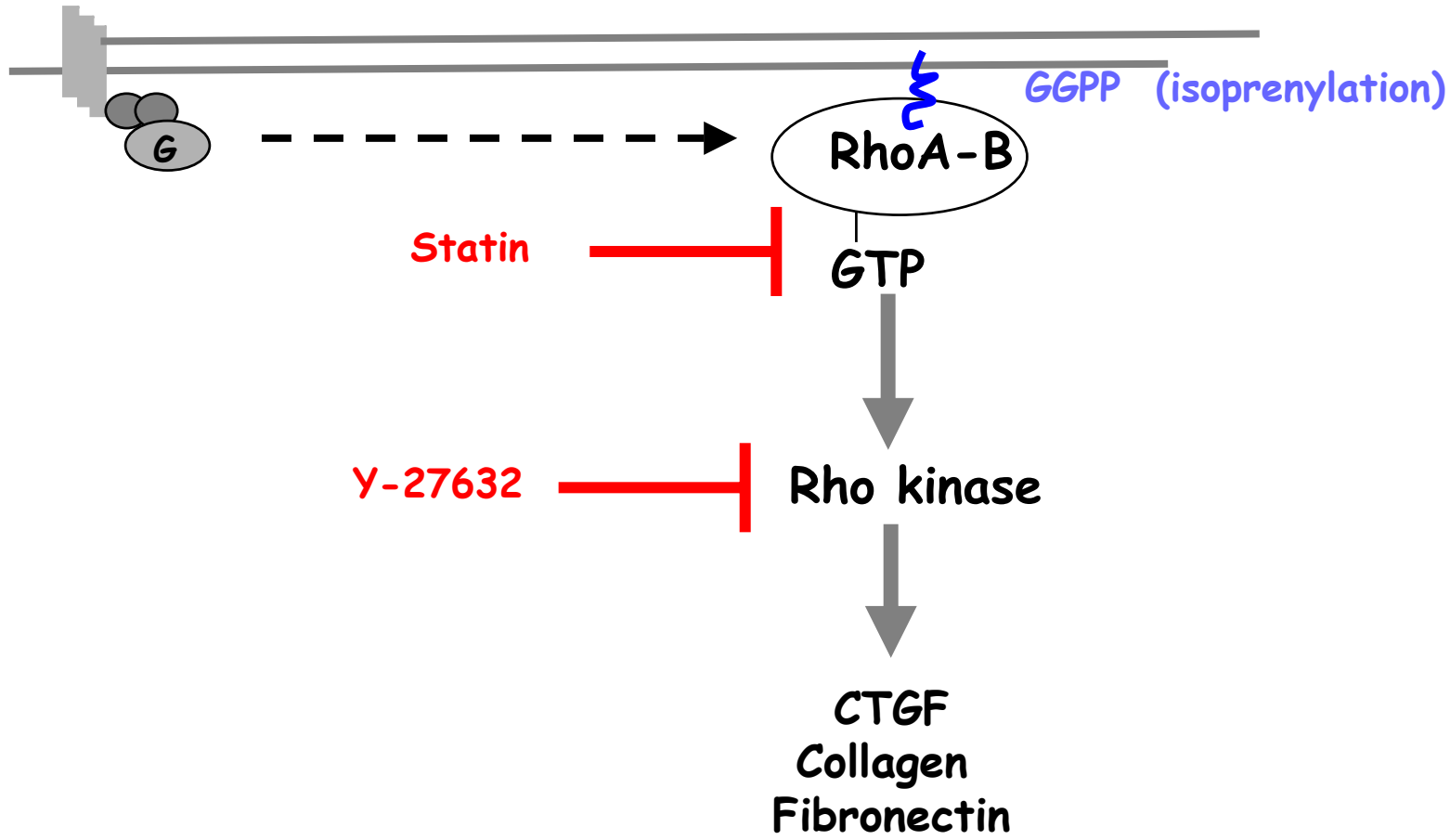

Reversion of Bleomycin-induced lung fibrosis in C57B6 mice using Rho/ROCK inhibitors

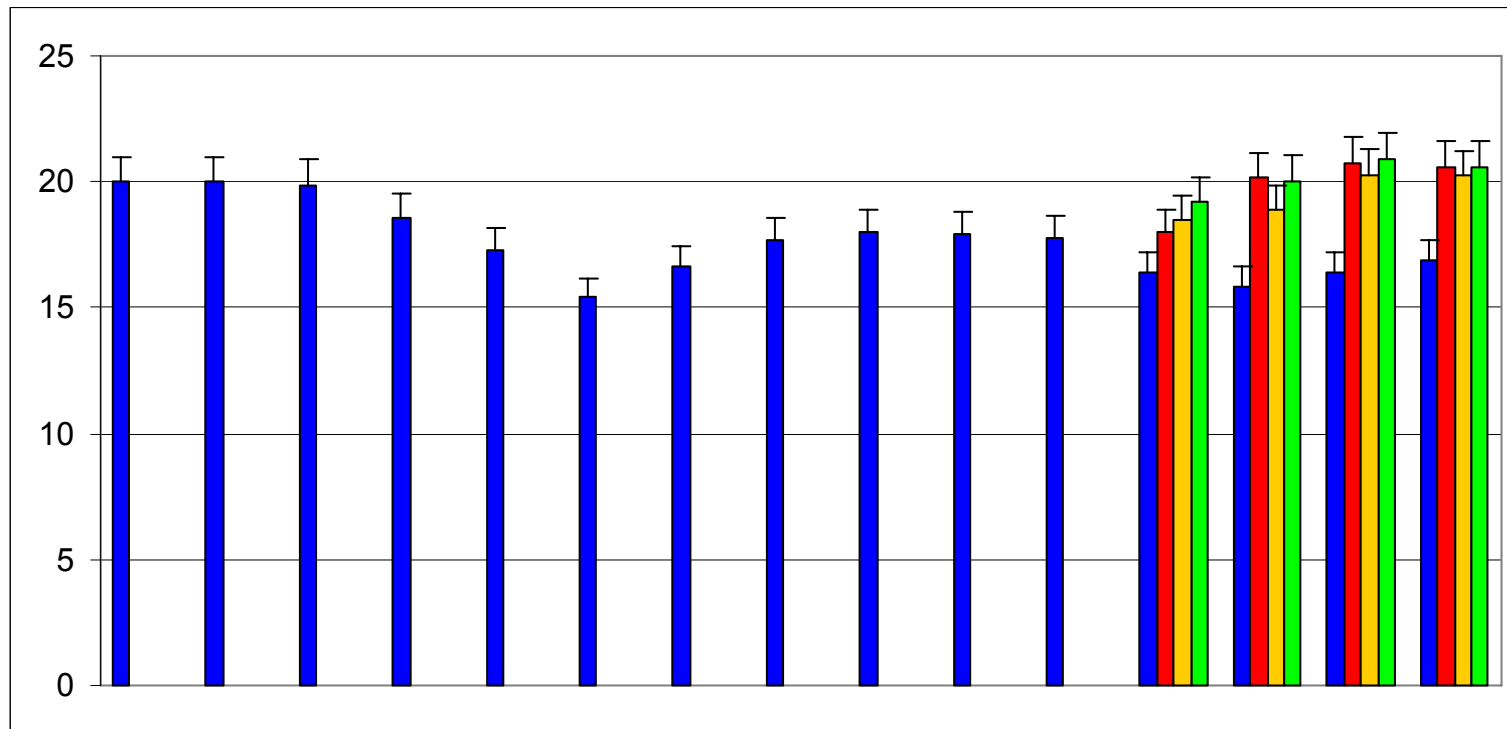
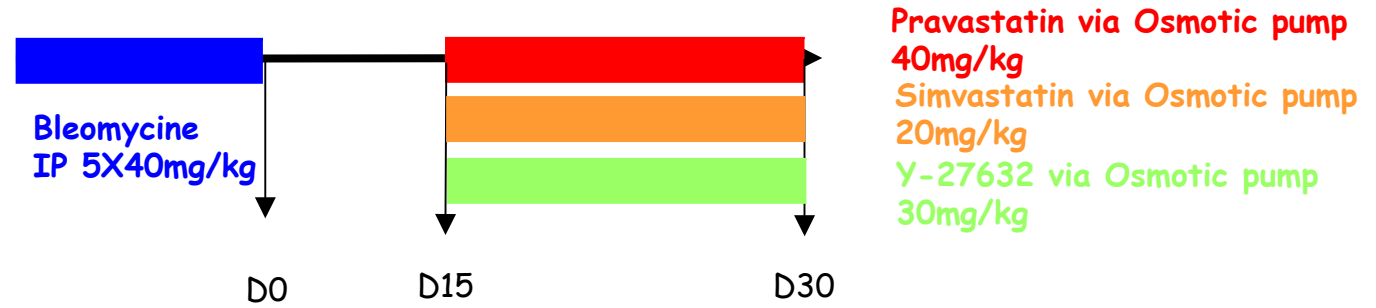

Mice Survival curves Exp2

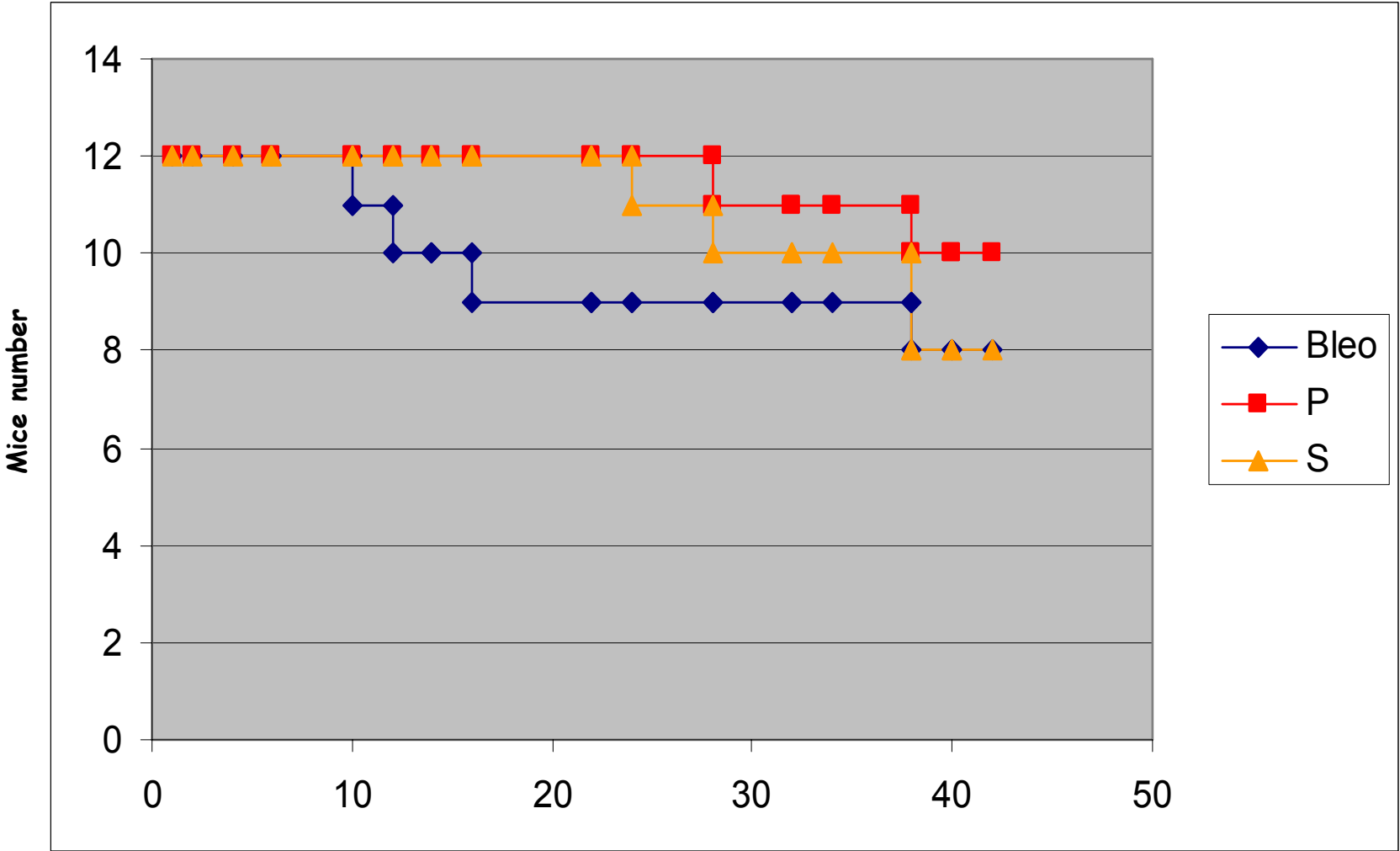

Bleo

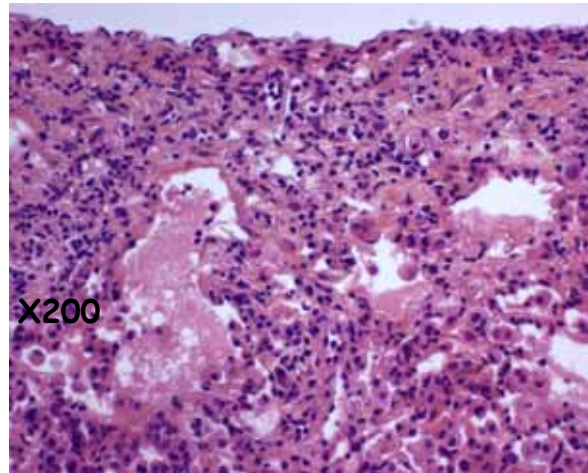
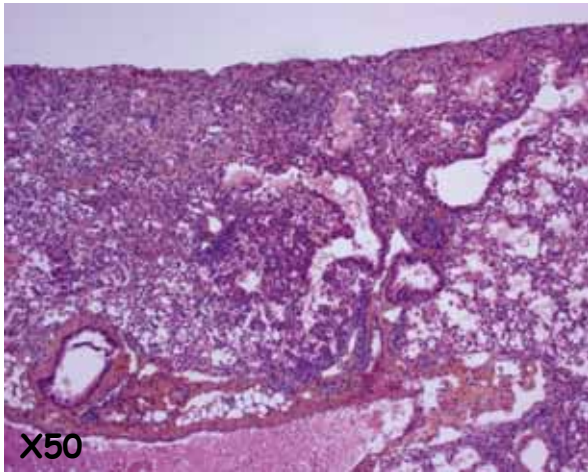

Sub-pleural fibrosis
Vessels remodelling

Prava

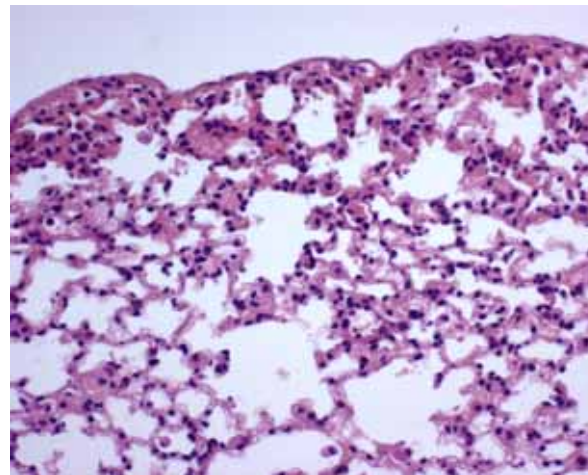
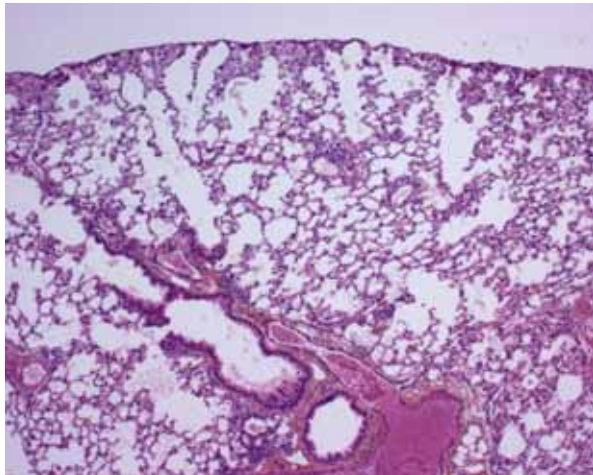

Alveolitis + macrophages

Simva

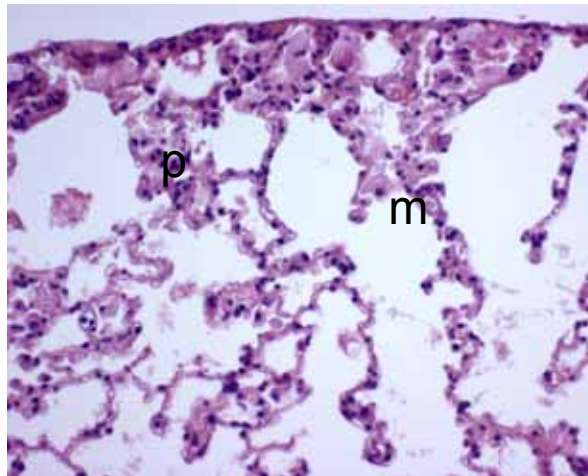
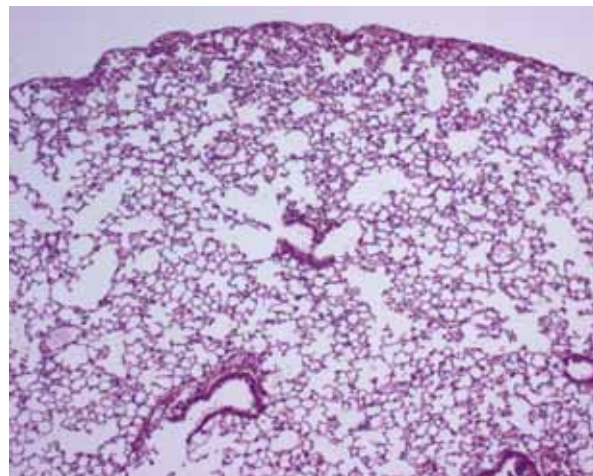

Alveolitis + poly + macrophages:

Mice Survival curves

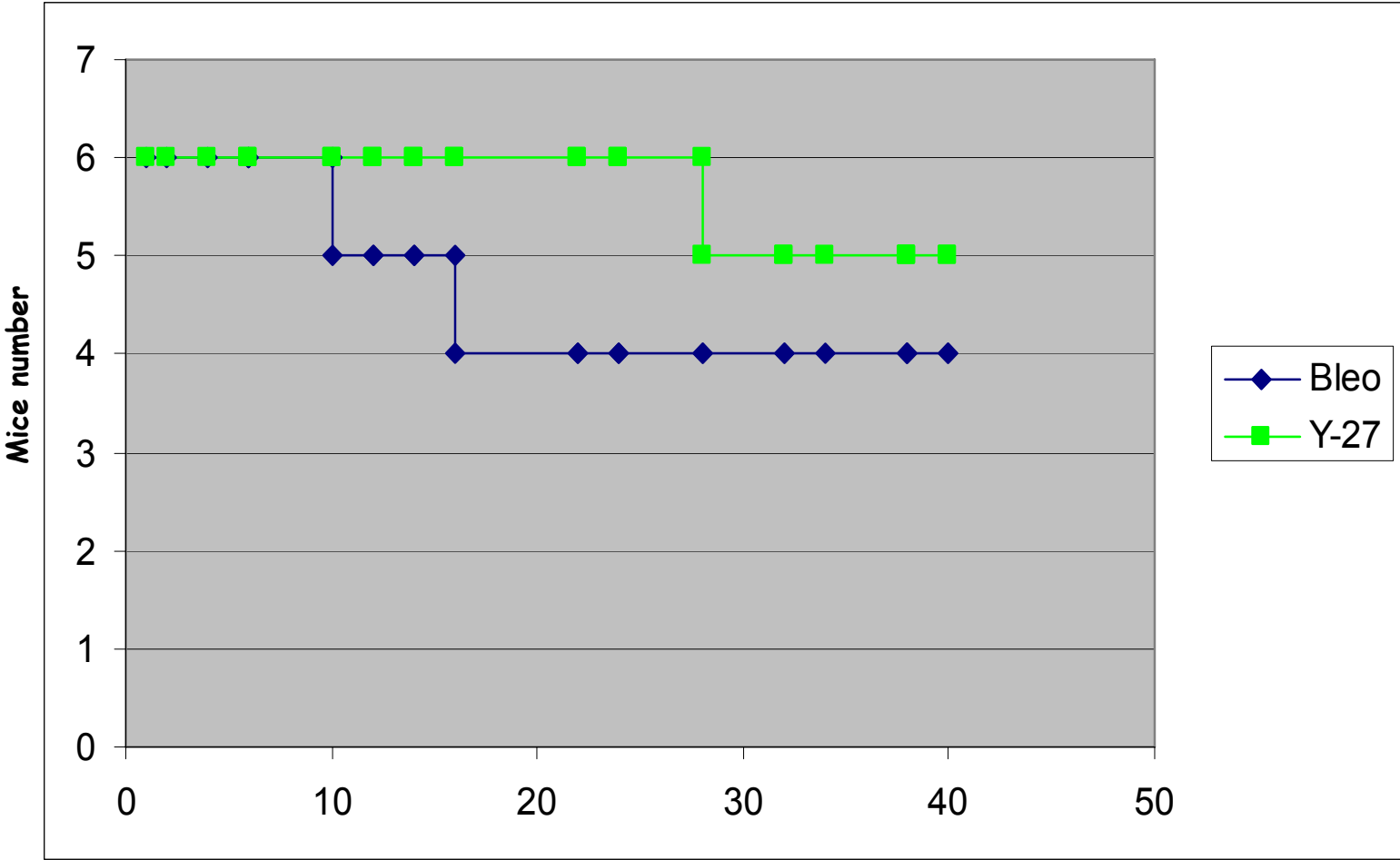

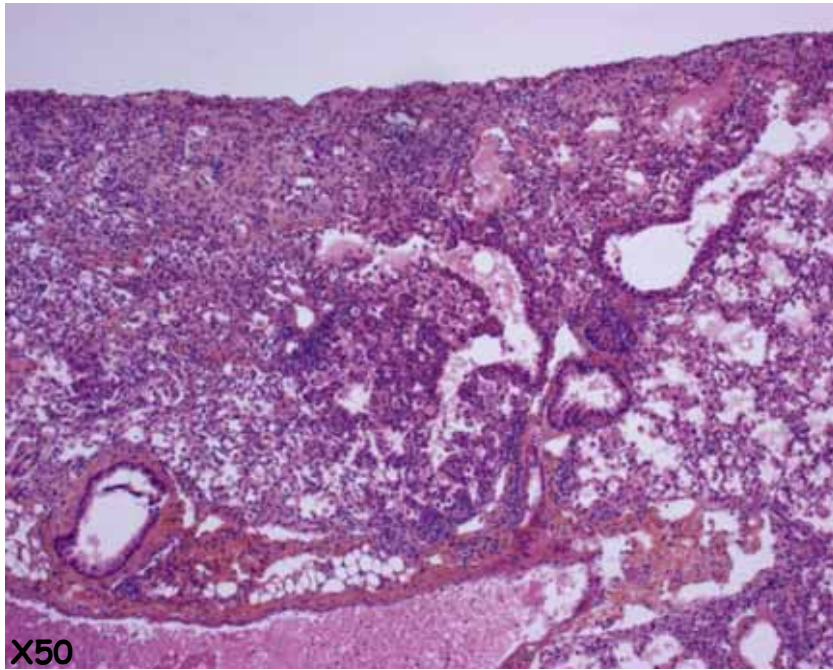

Bleo

X50

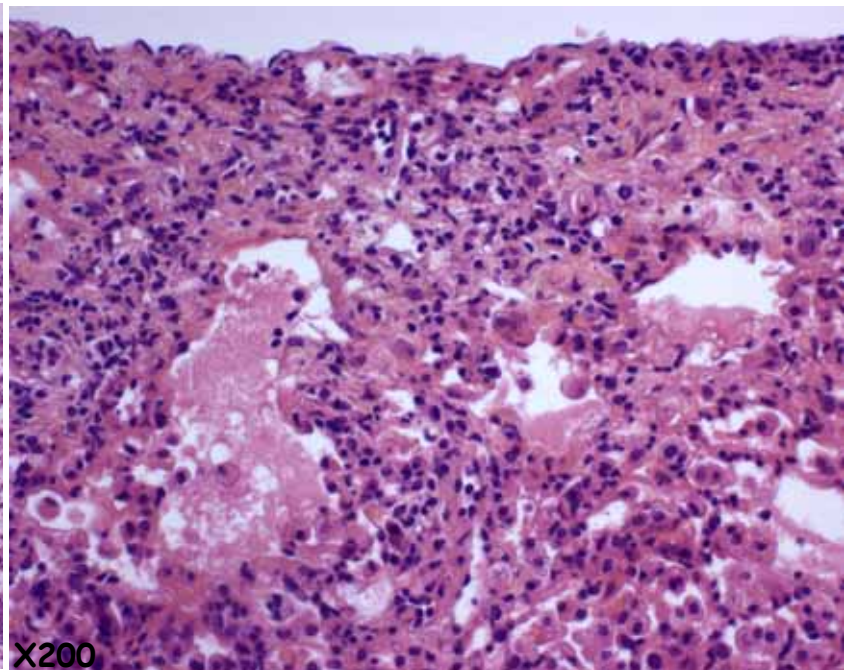

X200

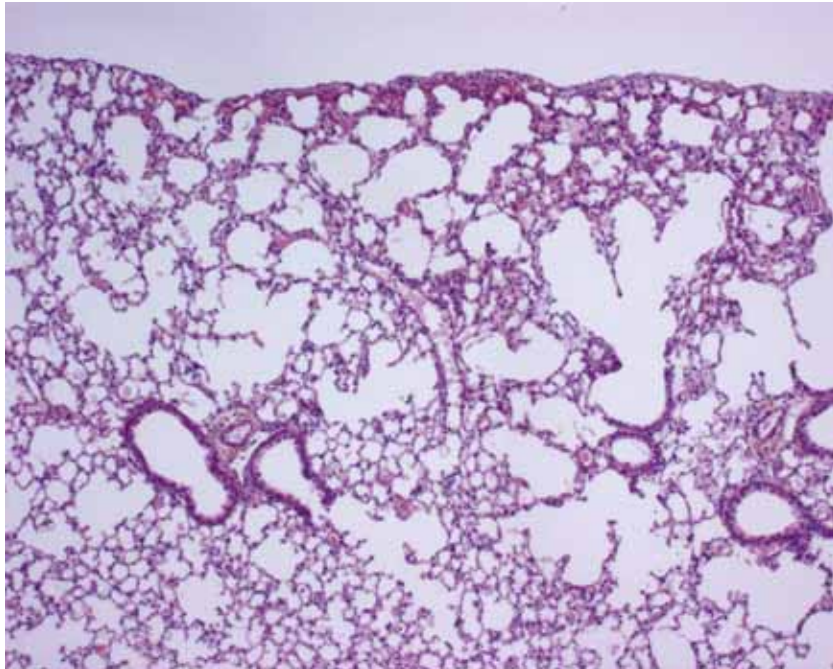

Y-27632

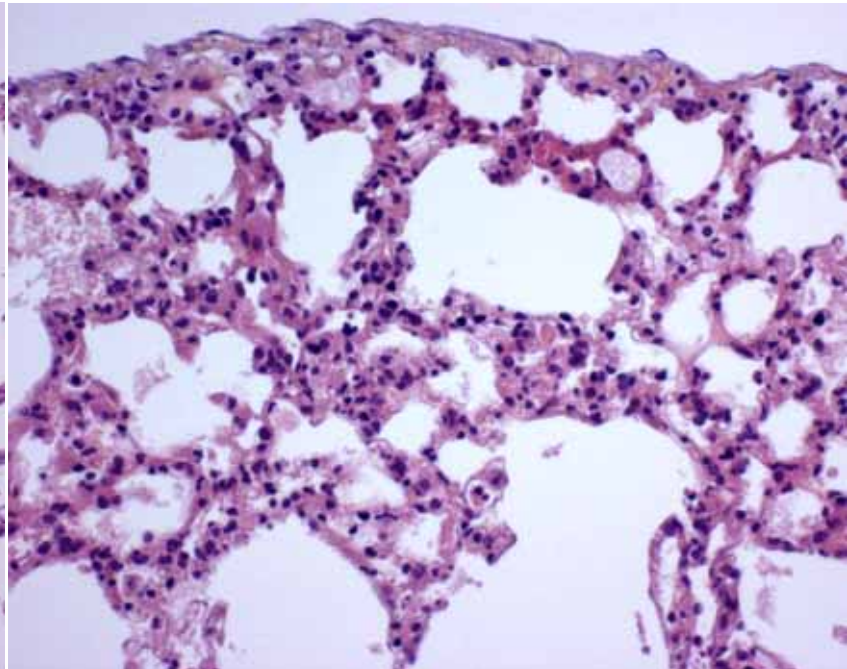

Prevention of Bleomycin-induced lung fibrosis in C57B6mice using Rho inhibitors

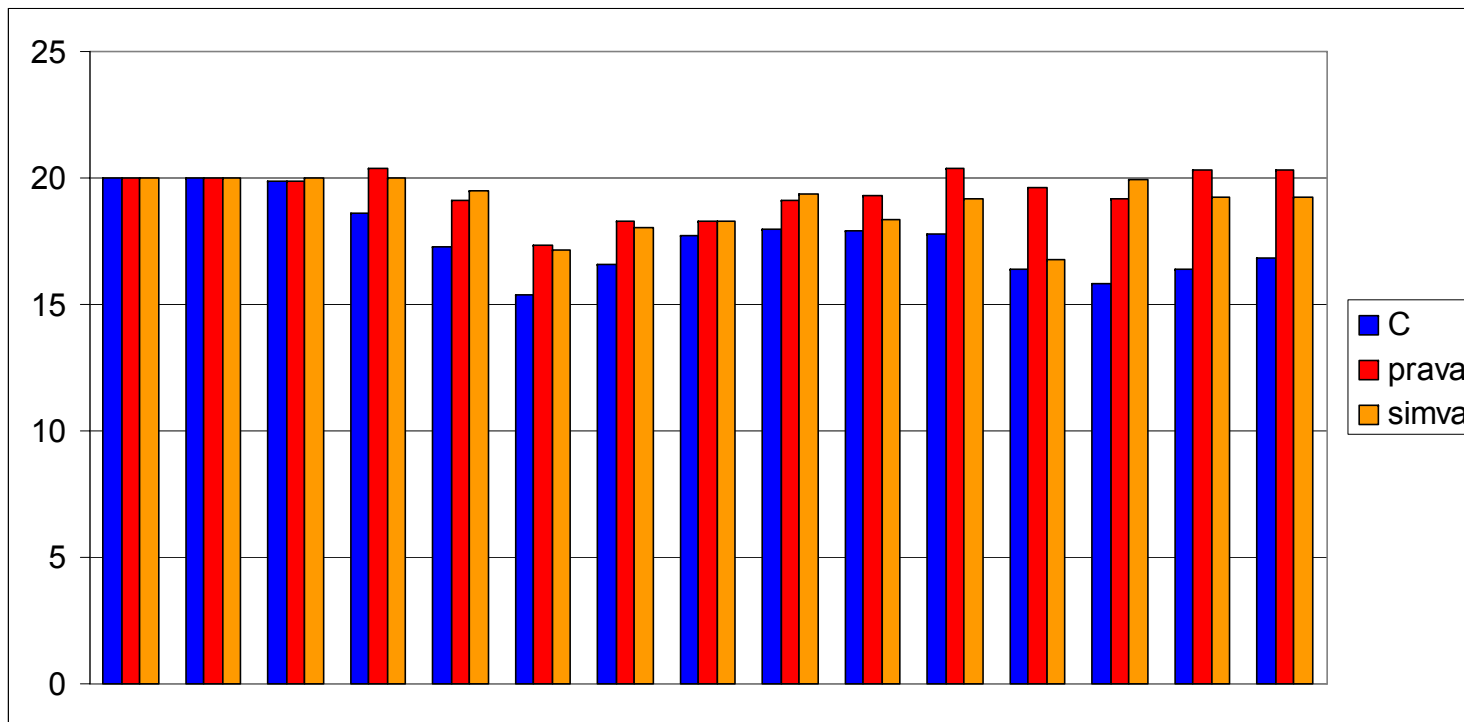
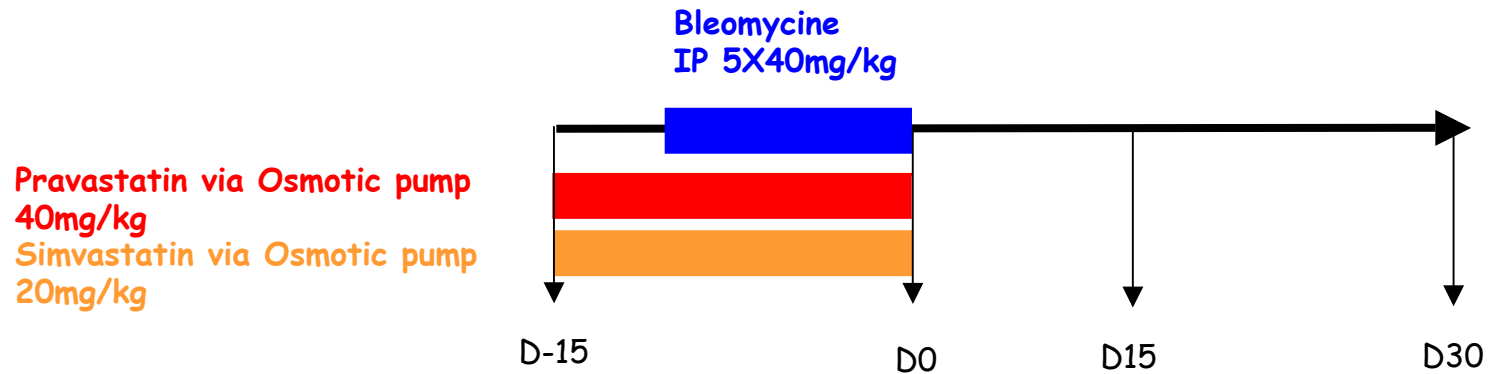

Mice Survival curves

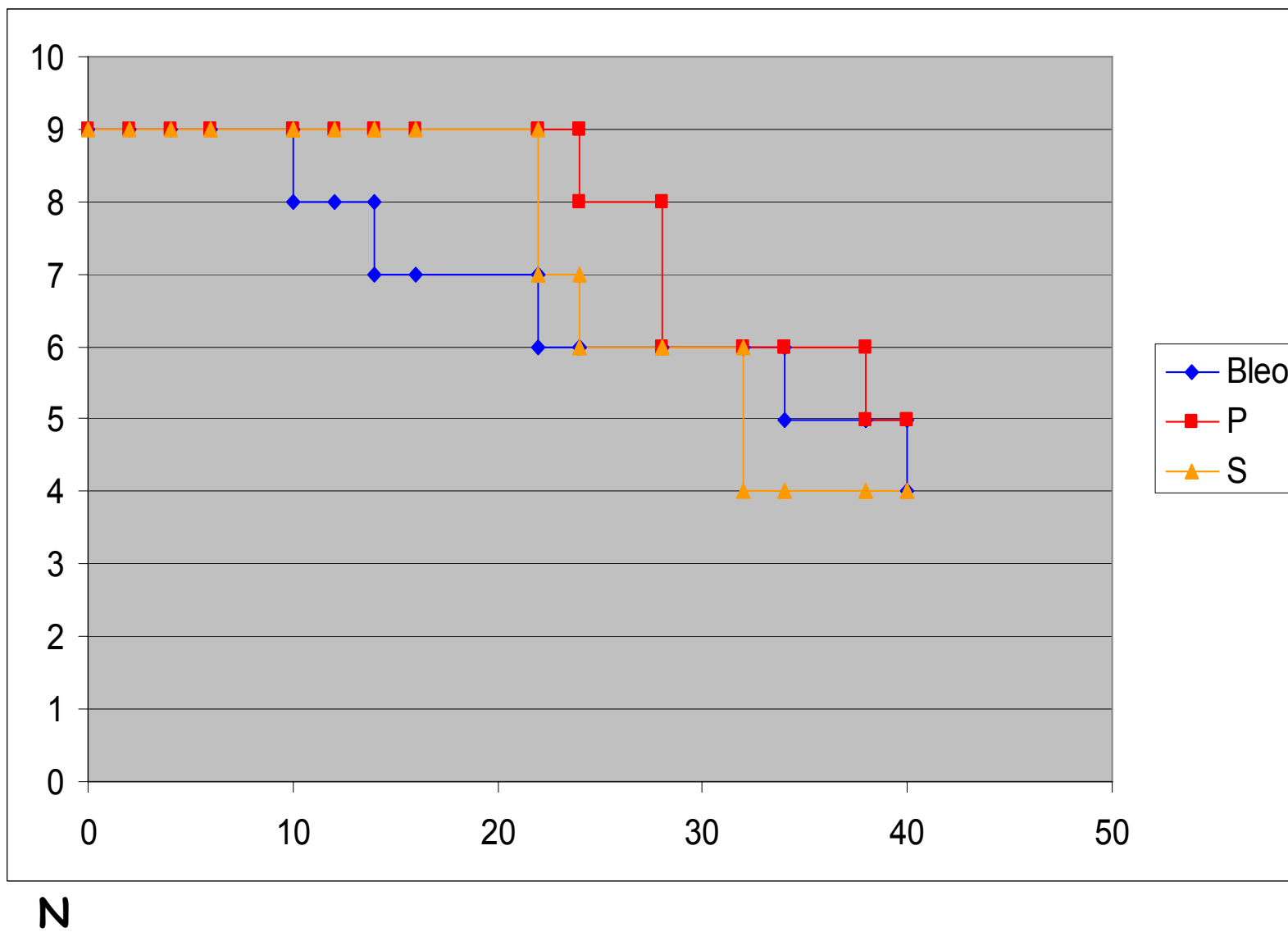

Bleo D30

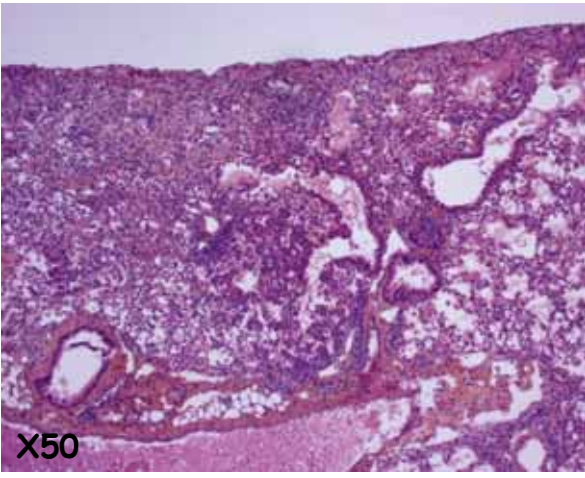

X200

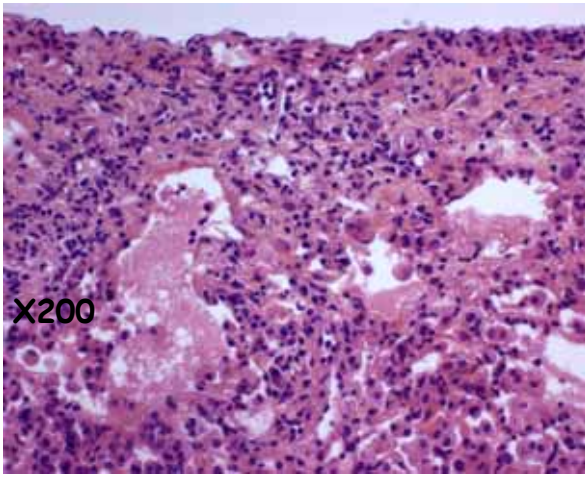

Sub-pleural fibrosis
Vessels remodelling

Prava D30

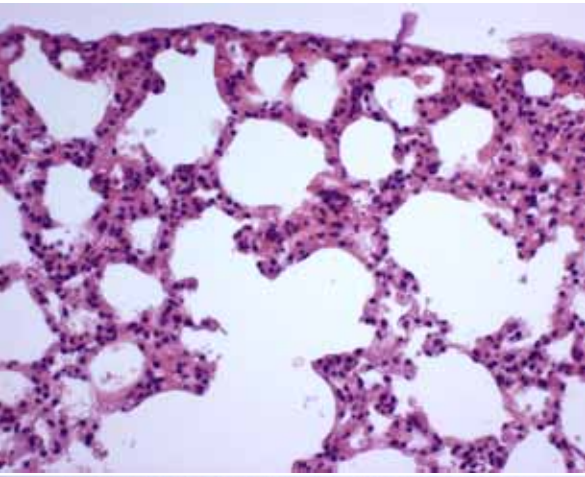
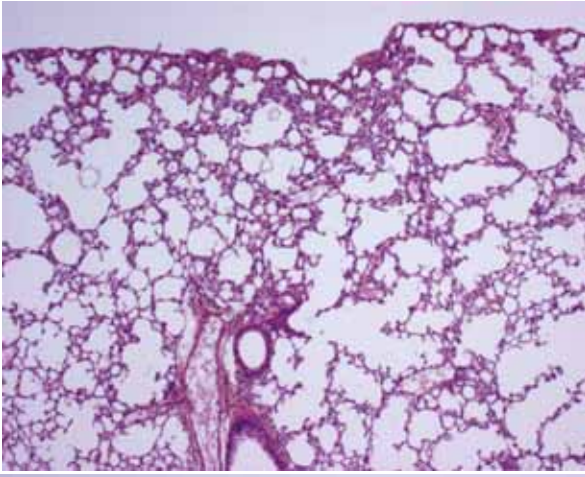

Oedema

Simva D30

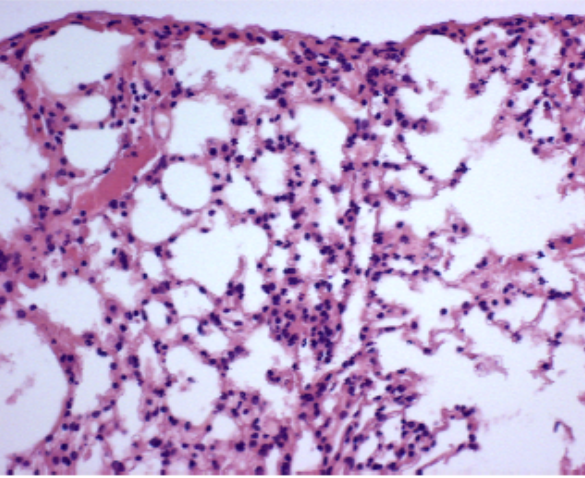
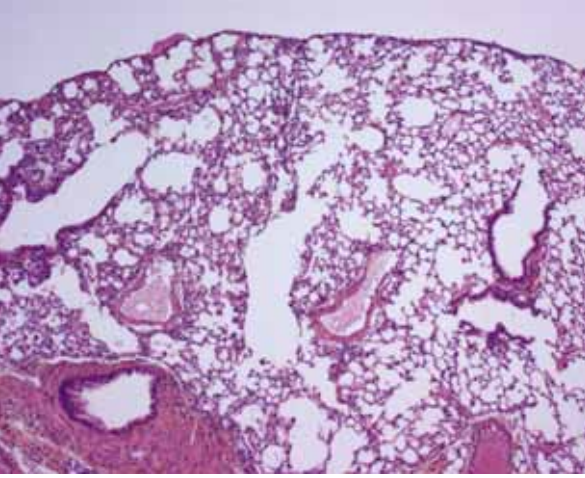

Metaplastic reaction (pre-cancerous lesion) in 2 Simvastatin treated mice

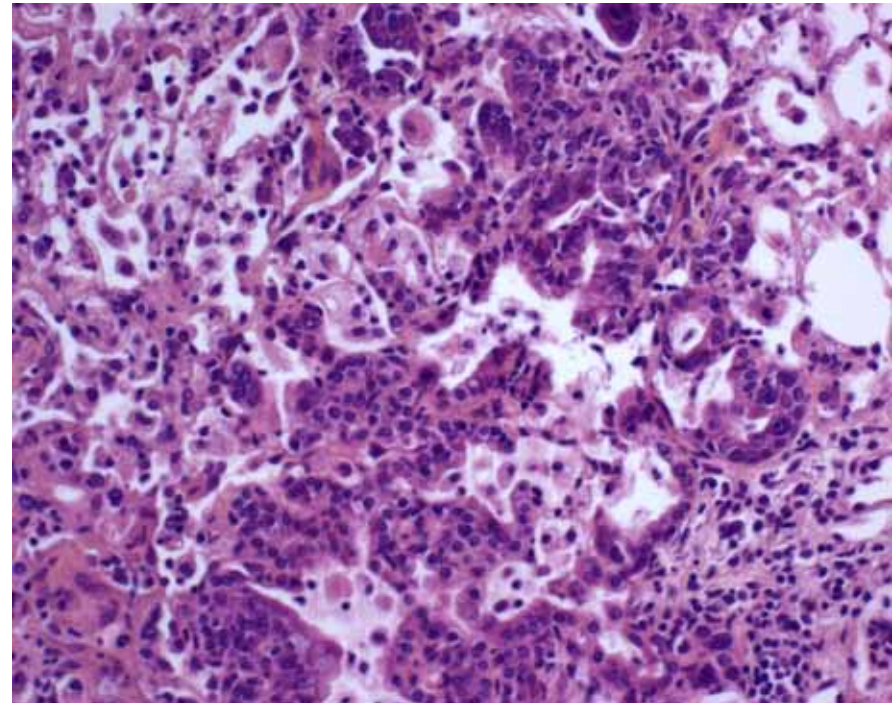
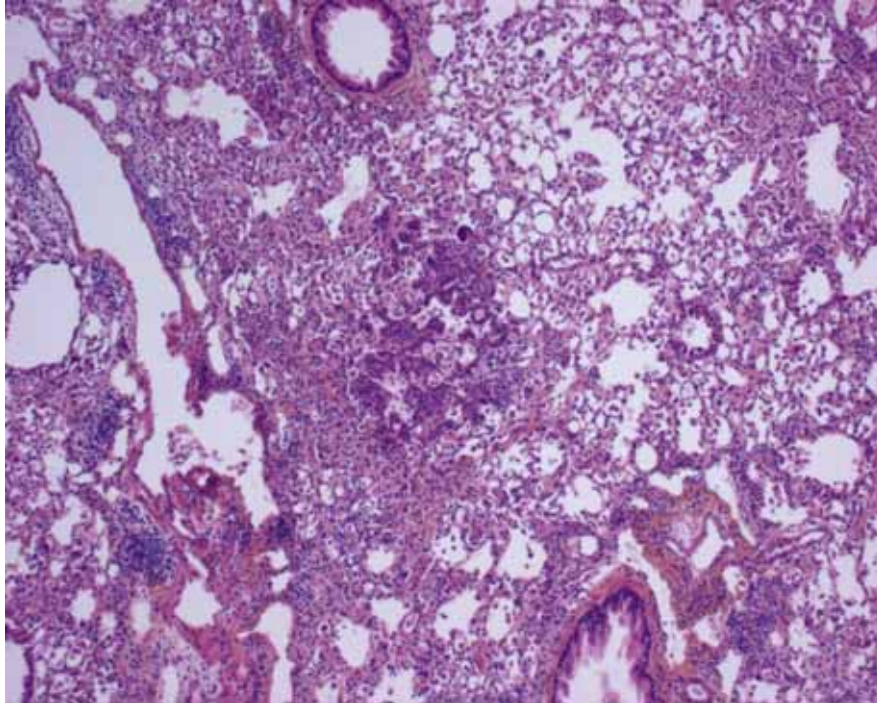

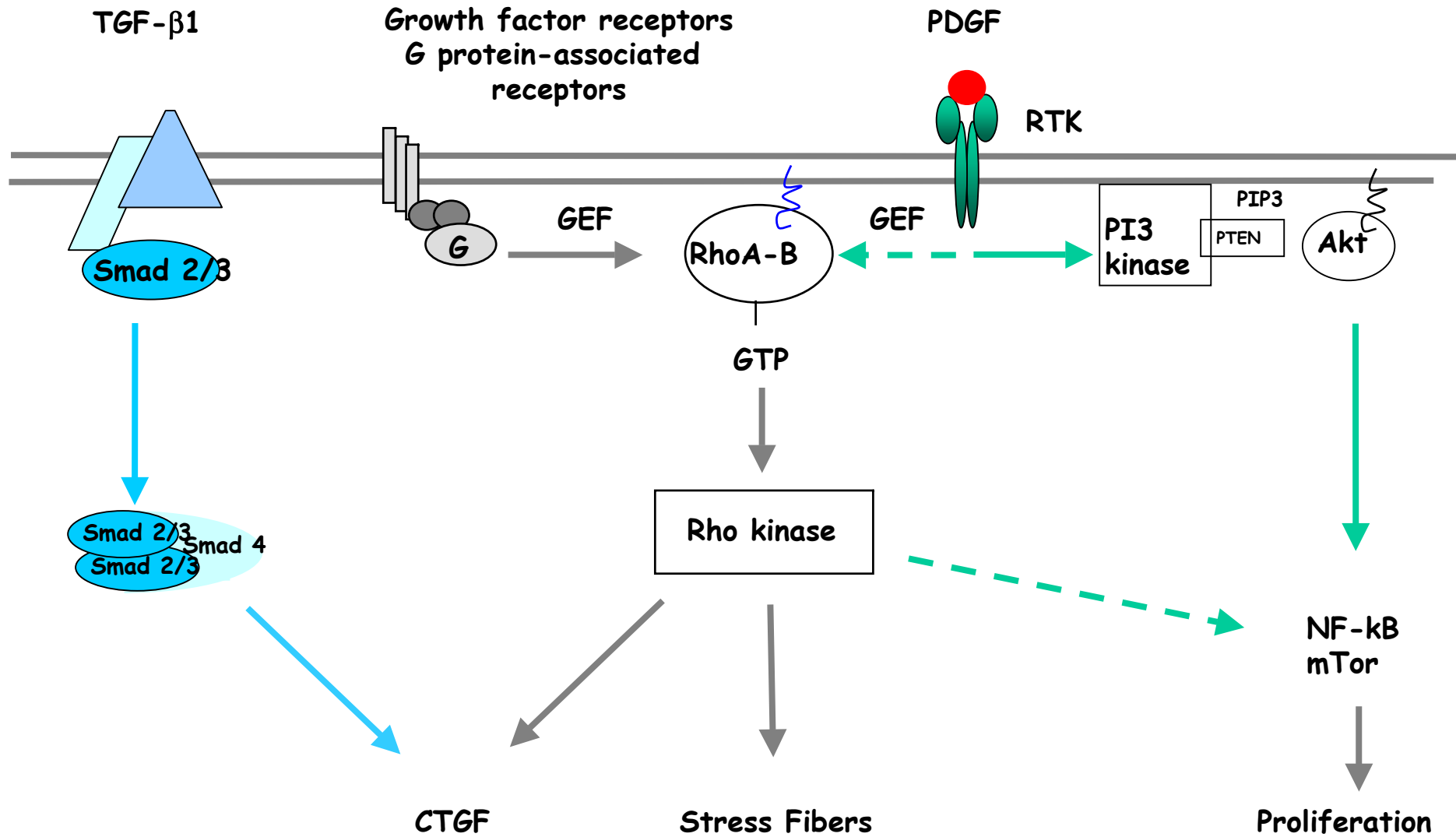

Ongoing experiments...

Lung fibrosis

Loredana Costa

Monica Mangoni

1- Radiation-induced lung fibrosis: thorax irradiation 16-17 Gy
Etude histologique: 15, 26, 36 w

2- Mixing cocktails: Rho and PDGF-R inhibition

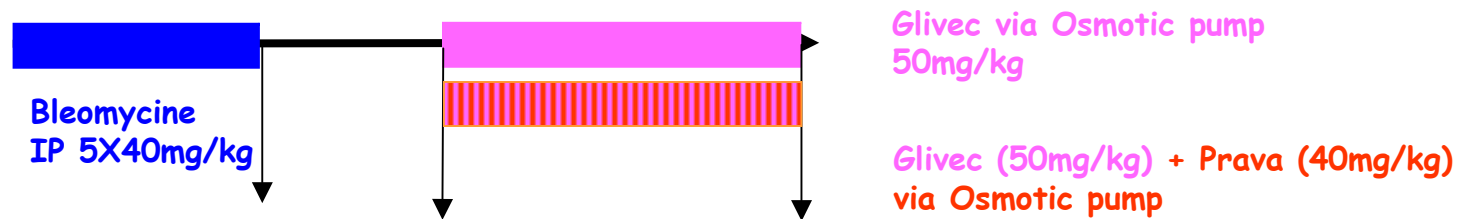

3- Sanofi-Aventis: New ROCK inhibitor

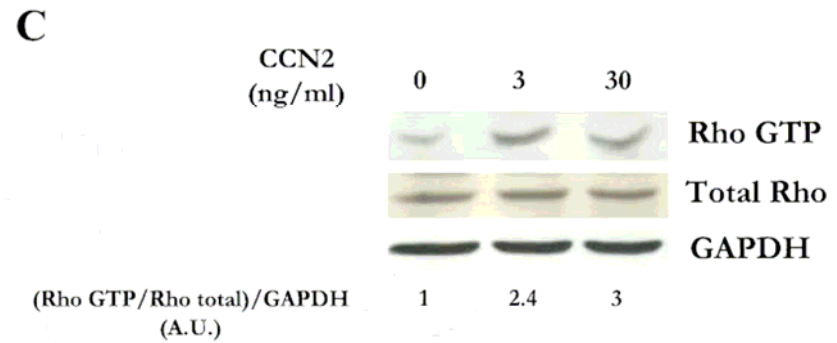
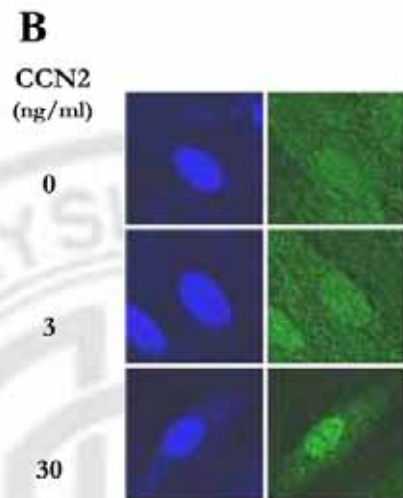
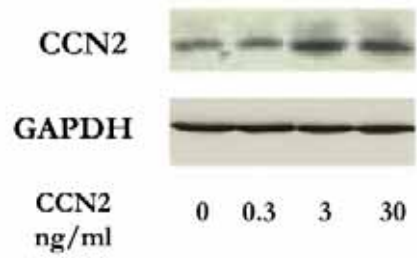
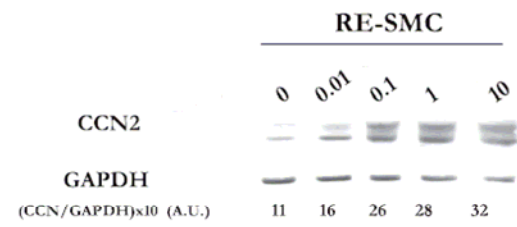

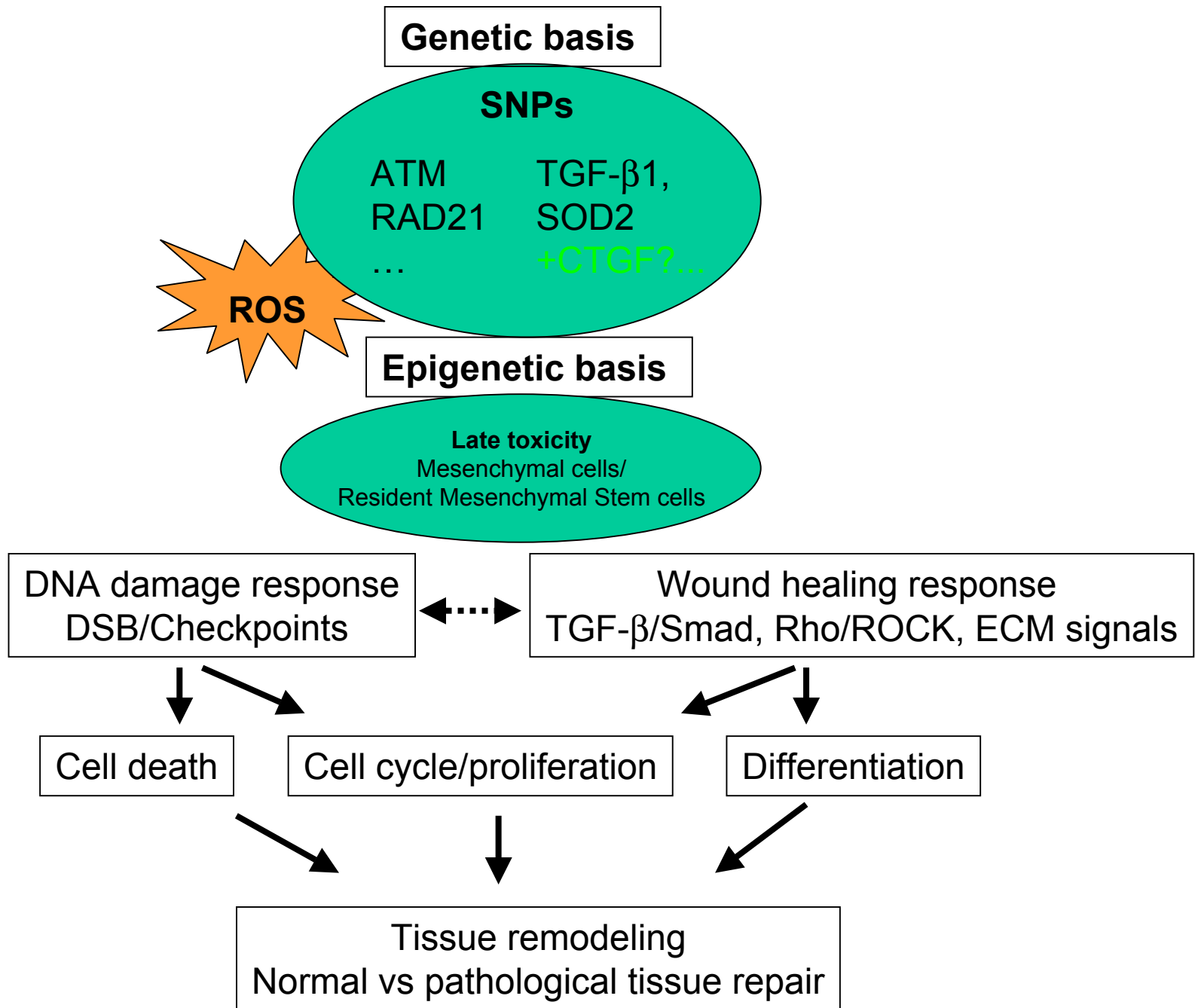

WT

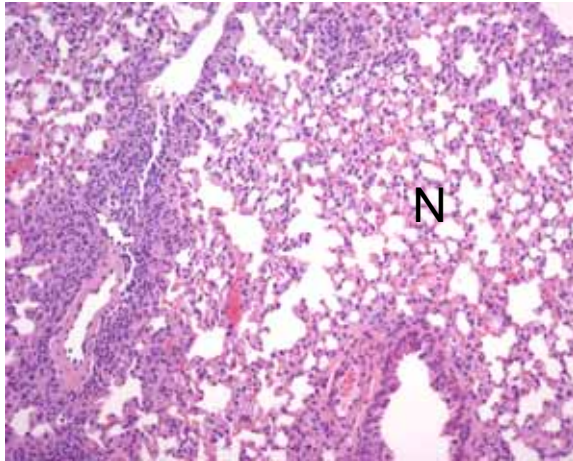
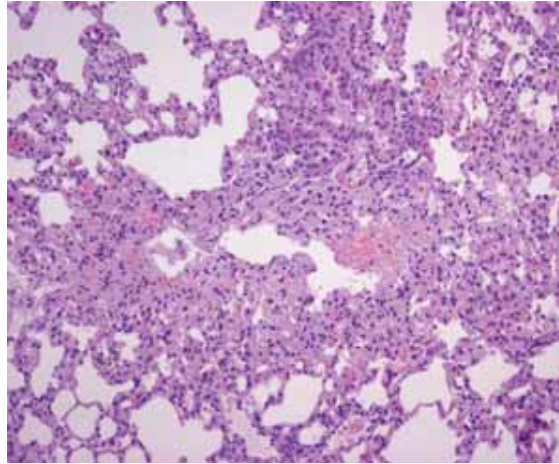

Rad21^{+/-}

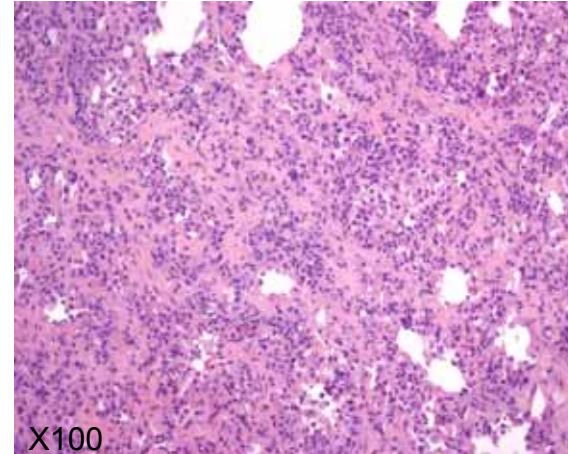

X100

Rec8^{+/-}

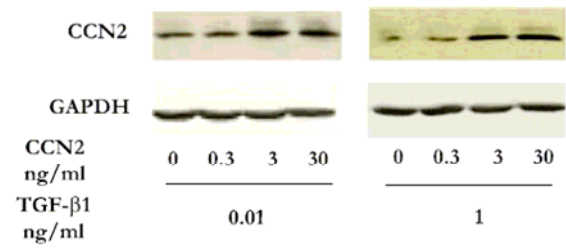

B

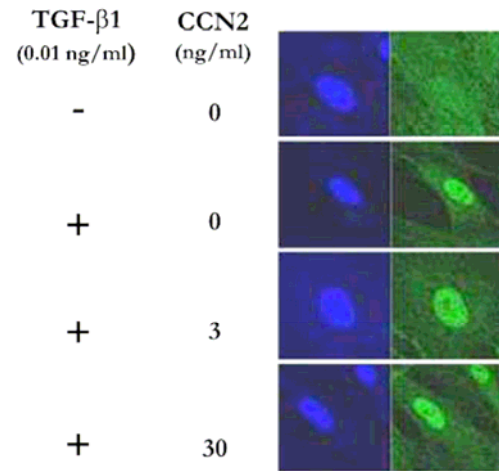

C

